

## 2009 WK - Engine, 6.1L/Removal

# REMOVAL

1. Remove the strut tower support (1).

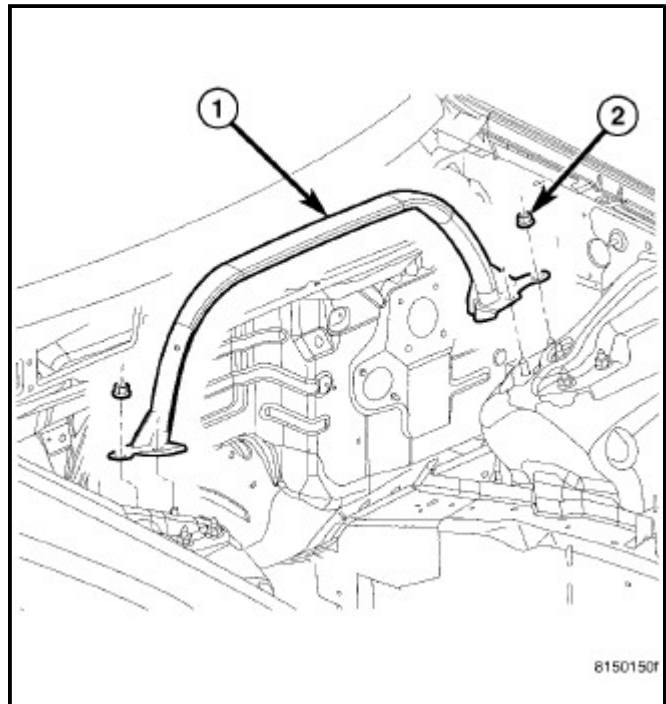

2. Remove the engine covers (1).

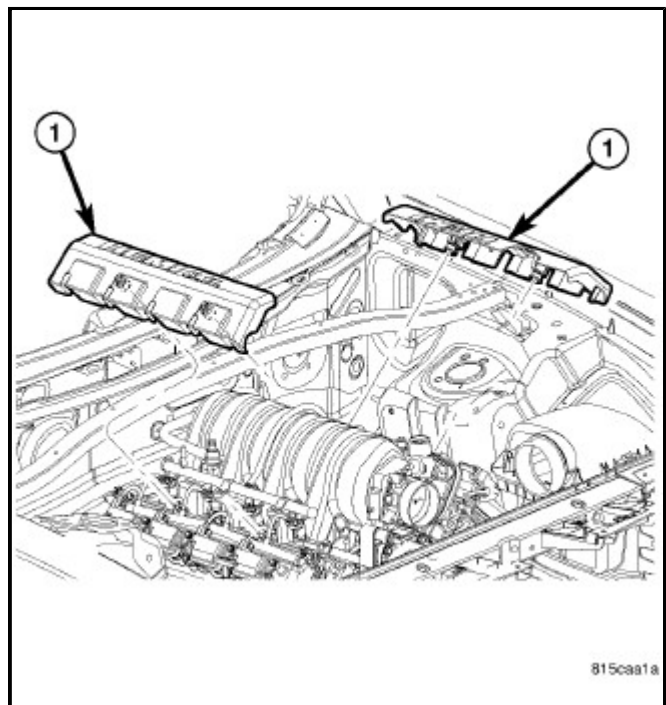

3. Perform the Fuel System Pressure Release

procedure ([Refer to 14 - Fuel System/Fuel Delivery - Standard Procedure](#))

4. Disconnect the battery negative cable.
5. Remove the air cleaner resonator and duct work as an assembly.
6. Drain the cooling system ([Refer to 07 - Cooling - Standard Procedure](#))
7. Remove the accessory drive belt ([Refer to 07 - Cooling/Accessory Drive/BELT, Serpentine - Removal](#))
8. Remove radiator fan shroud ([Refer to 07 - Cooling/Engine/FAN, Cooling - Removal](#))

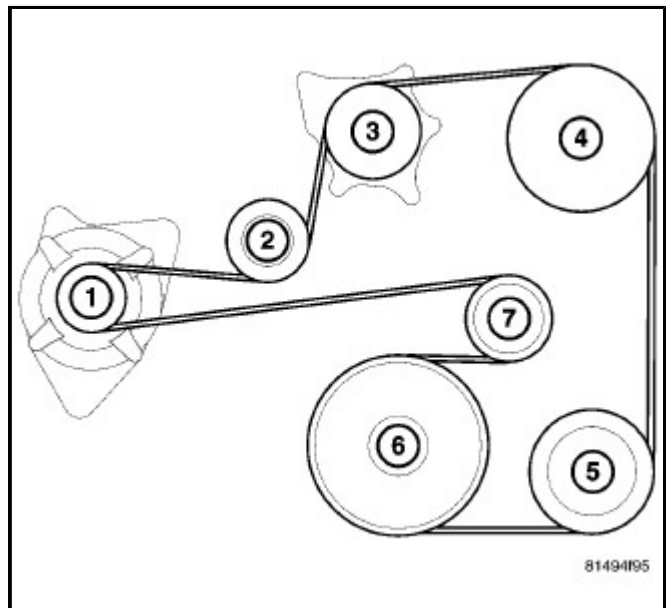

9. Remove the A/C compressor while leaving the lines attached. Secure compressor out of the way.

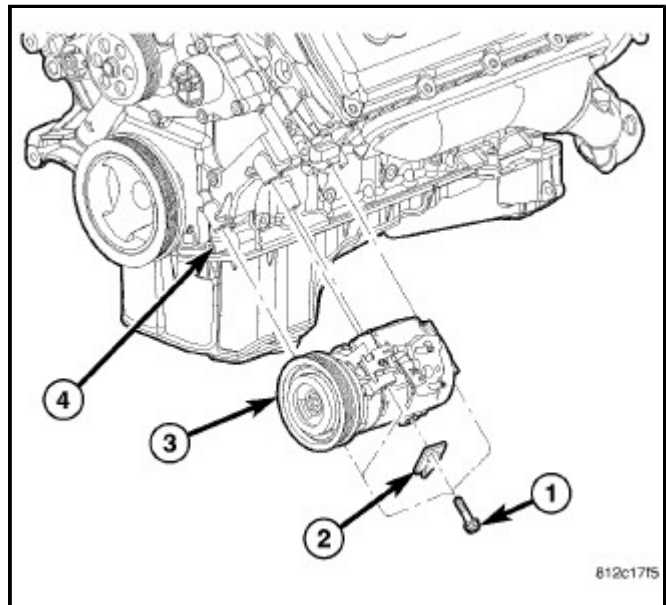

10. Remove generator assembly. ([Refer to 08 - Electrical/8F - Engine Systems/Charging/GENERATOR - Removal](#))
11. Remove the intake manifold and IAFM as an assembly. ([Refer to 09 - Engine/Manifolds/MANIFOLD, Intake - Removal](#))
12. Remove the ground wires from the rear of each cylinder head.

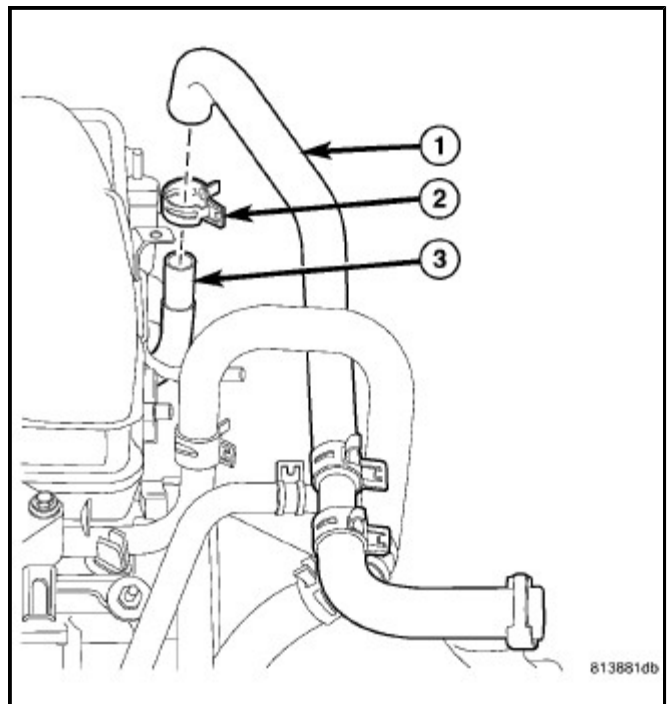
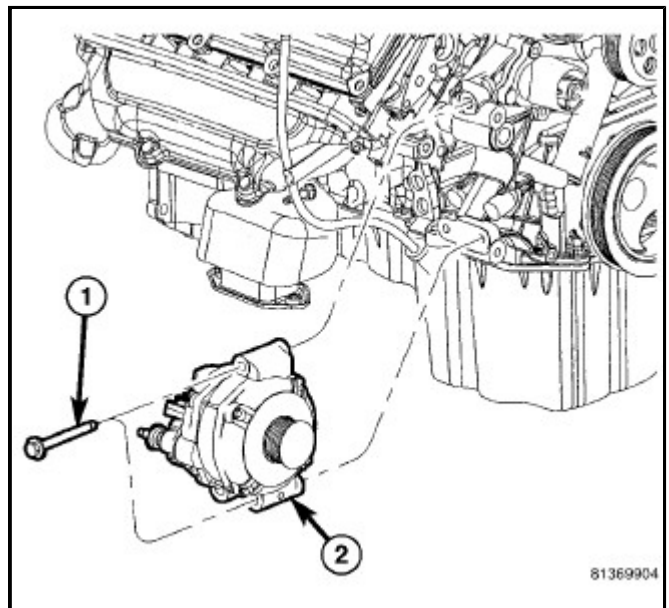

13. Disconnect the heater hoses (1).

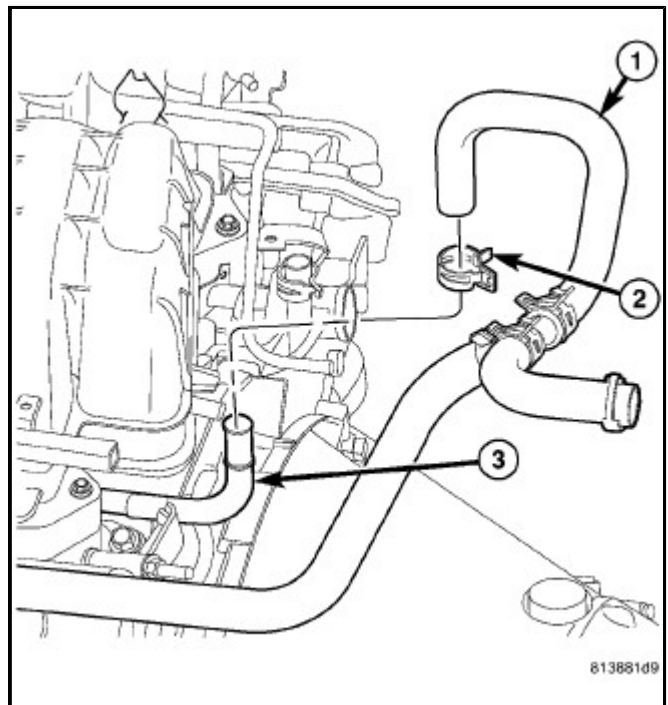

**NOTE:** It is not necessary to disconnect P/S hoses from pump, for P/S pump removal.

14. Remove the power steering pump and set aside.
15. Disconnect the fuel supply line. ([Refer to 14 - Fuel System/Fuel Delivery/FITTING, Quick Connect - Standard Procedure](#))
16. Raise and support the vehicle on a hoist and drain the engine oil.
17. Remove engine front mount to frame bolts (3) and nuts.
18. Disconnect the transmission oil cooler lines from their retainers at the oil pan bolts.

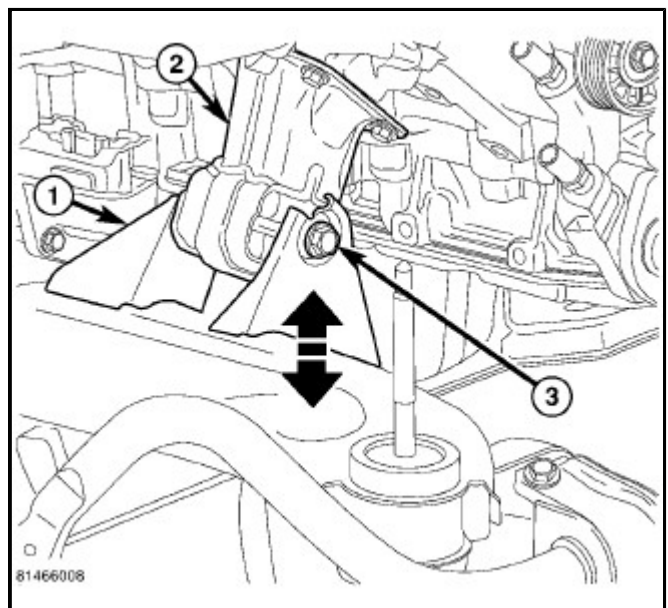

19. Disconnect exhaust pipe at manifolds.
20. Disconnect the starter wires. Remove starter motor (1) ([Refer to 08 - Electrical/8F - Engine Systems/Starting/STARTER - Removal](#))

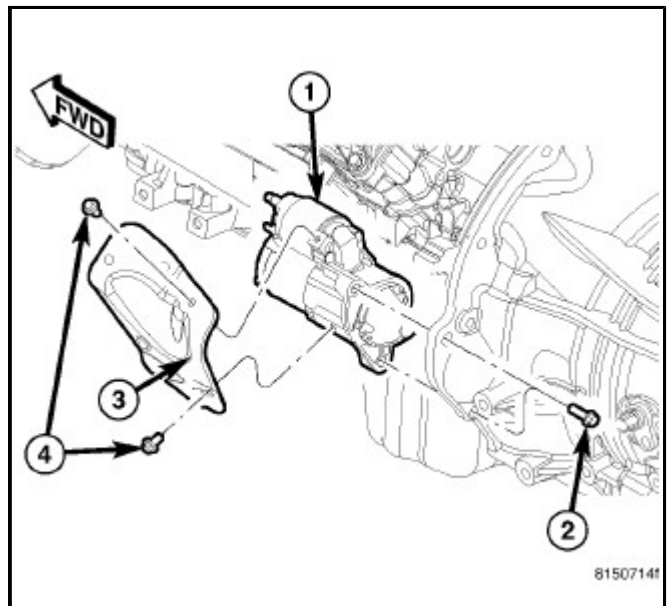
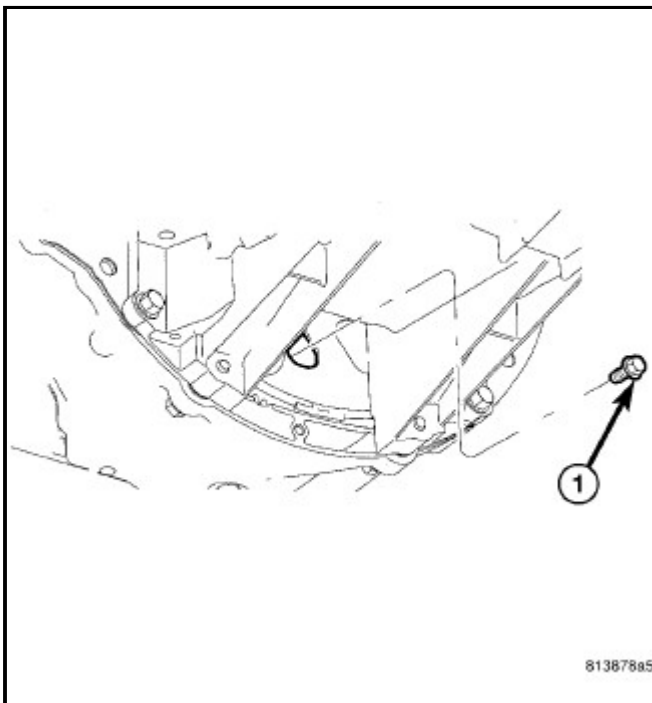

21. Remove the structural dust cover. ([Refer to 09 - Engine/Engine Block/COVER, Structural Dust - Removal](#)).
22. Remove drive plate to converter bolts.
23. Remove the oil pan to transmission bolts (1).
24. Remove transmission bell housing to engine block bolts (2).
25. Lower the vehicle.



## Expanded details section

### 14 - Fuel System / Fuel Delivery, Gas/Standard Procedure

# FUEL SYSTEM PRESSURE RELEASE

Use the following procedure if the fuel injector rail is, or is not equipped with a fuel pressure test port.

1. Remove the fuel fill cap.
2. Remove the fuel pump relay from the Power Distribution Center (PDC). For location of the fuel pump relay, refer to label on the underside of the PDC cover or [\(Refer to 04 - Vehicle Quick Reference/Fuse Locations and Types - Specifications\)](#)
3. Start and run the engine until it stalls.
4. Attempt restarting the engine until it will no longer run.
5. Turn the ignition key to the OFF position.
6. Place a rag or towel below the fuel line quick-connect fitting at the fuel rail.
7. Disconnect the quick-connect fitting at the fuel rail [\(Refer to 14 - Fuel System/Fuel Delivery/FITTING, Quick Connect - Standard Procedure\)](#)
8. Return fuel pump relay to PDC.

**NOTE:** One or more Diagnostic Trouble Codes (DTC) may have been stored in the PCM memory due to fuel pump relay removal. A diagnostic scan tool must be used to erase a DTC.

## 07 - Cooling/Standard Procedure

# DRAINING

**WARNING:** Do not remove the cylinder block drain plugs or loosen the radiator draincock with system hot and under pressure. Serious burns from coolant can occur.

1. DO NOT remove radiator cap first. With engine cold, raise vehicle on a hoist and locate radiator draincock.

**NOTE:** Radiator draincock is located on the right/lower side of radiator facing to rear of vehicle.

2. Attach one end of a hose to the draincock. Put the other end into a clean container. Open draincock and drain coolant from radiator. This will empty the coolant reserve/overflow tank. The coolant does not have to be removed from the tank unless the system is being refilled with a fresh mixture. When tank is empty, remove radiator cap and continue draining cooling system.

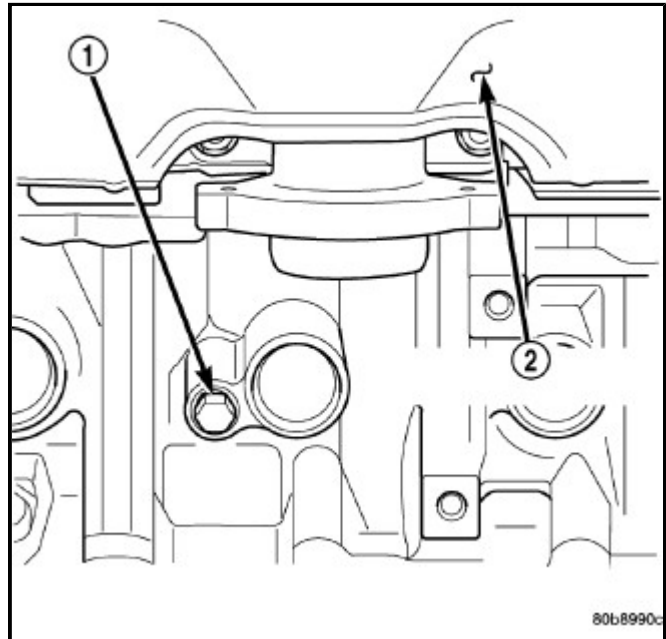

80b8990c



## 07 - Cooling / Accessory Drive / BELT, Serpentine/Removal

### 5.7L/6.1L ENGINE

1. Remove the air intake tube between intake manifold and air filter assembly.
2. Using a suitable square drive tool, release the belt tension by rotating the tensioner (8)**clockwise**. Rotate belt tensioner (8) until belt (2) can be removed from pulleys .
3. Remove belt (2).
4. Gently release tensioner (8).

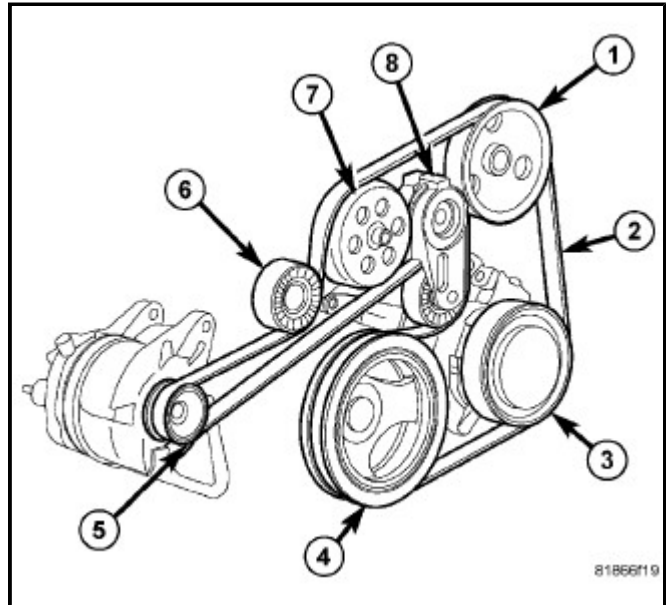

## 07 - Cooling/Engine/DRIVE, Fan/Removal

# REMOVAL

**NOTE:** The thermal viscous fan drive/fan blade assembly is attached (threaded) to water pump hub shaft.

1. Remove the accessory drive belt. [Refer to 07 - Cooling/Accessory Drive/BELT, Serpentine - Removal](#).
2. Remove fan blade/viscous fan drive assembly (2) from water pump using special tool [6958](#) spanner wrench and [8346](#) adapters (1), by turning mounting nut counterclockwise as viewed from front. Threads on viscous fan drive are **RIGHT HAND**.
3. Do not attempt to remove fan/viscous fan drive assembly (2) from vehicle at this time.
4. Do not unbolt fan blade assembly from viscous fan drive at this time.
5. Remove fan shroud to radiator bolts.
6. Remove fan shroud and fan blade/viscous fan drive assembly as a complete unit from vehicle.
7. After removing fan blade/viscous fan drive assembly (2), **do not** place viscous fan drive in horizontal position. If stored horizontally, silicone fluid in the viscous fan drive could drain into its bearing assembly and contaminate lubricant.

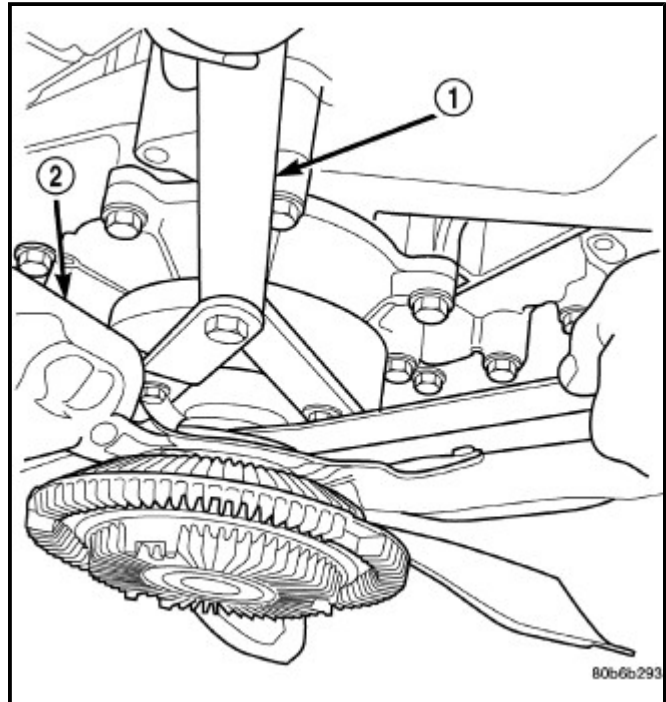

**CAUTION:** Do not remove water pump pulley-to-water pump bolts. This pulley is under belt tension.

8. Remove four bolts securing fan blade assembly to viscous fan drive .

## 08 - Electrical/8F - Engine Systems/Charging/GENERATOR/Removal

### 6.1L

☒ **Labor Operations:** Click to display a list of Labor Operations associated with this procedure

**WARNING:** Disconnect the negative cable from the battery before removing the battery output wire (B+ wire) from the generator. Failure to do so can result in injury or damage to the electrical system.

1. Disconnect and isolate the negative battery cable.
2. Remove the air cleaner ([Refer to 09 - Engine/Air Intake System - Removal](#)).
3. Remove the serpentine belt ([Refer to 07 - Cooling/Accessory Drive/BELT, Serpentine - Removal](#)).

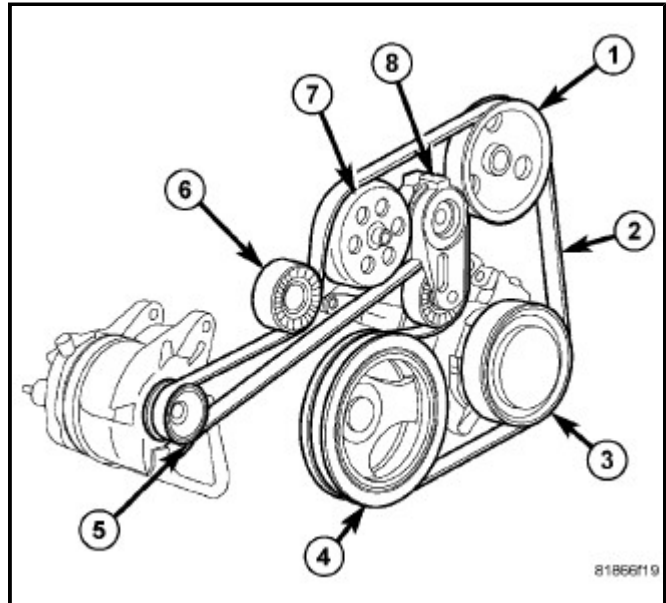

4. Unsnap the plastic insulator cap from the B+ output terminal.
5. Remove the B+ terminal mounting nut at the rear of the generator. Disconnect the terminal from the generator.
6. Disconnect the field wire connector (3) at the rear of the generator by pushing on the connector tab.
7. Remove two generator mounting bolts (1).
8. Remove the generator (2) from vehicle.

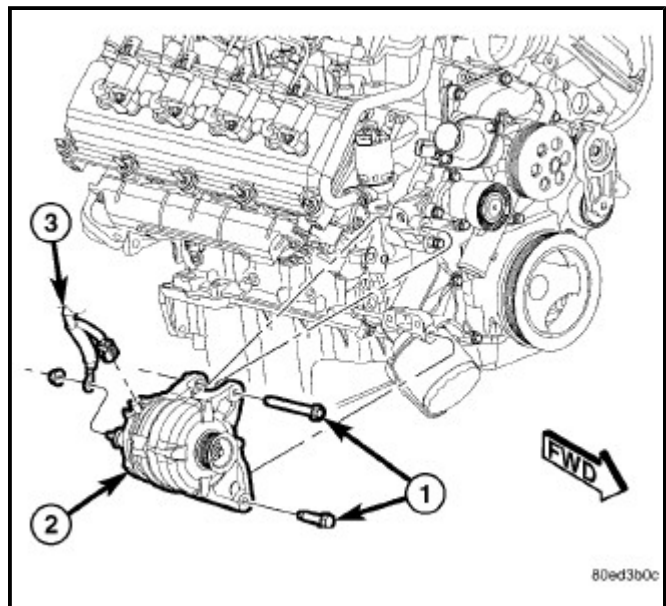

## 09 - Engine, 6.1L / Manifolds / MANIFOLD, Intake/Removal

### REMOVAL

1. Remove the engine covers (1), they snap off of the fuel rail ball studs.

**WARNING:** The fuel system is under constant pressure even with engine off. Before servicing the fuel rail, fuel system pressure must be released.

2. Perform the fuel pressure release procedure ([Refer to 14 - Fuel System/Fuel Delivery - Standard Procedure](#))
3. Disconnect and isolate the negative battery cable.

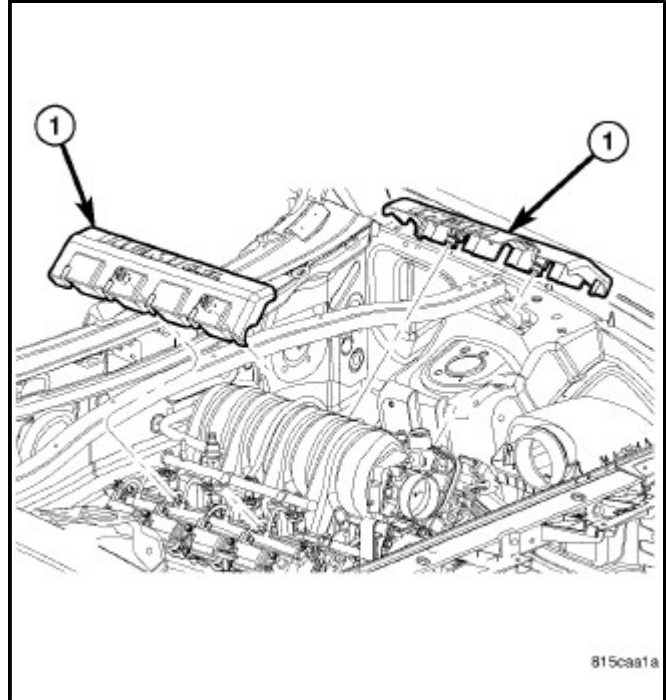

4. Disconnect the intake air temperature (IAT) sensor connector (2).
5. Remove the clean air tube (1).

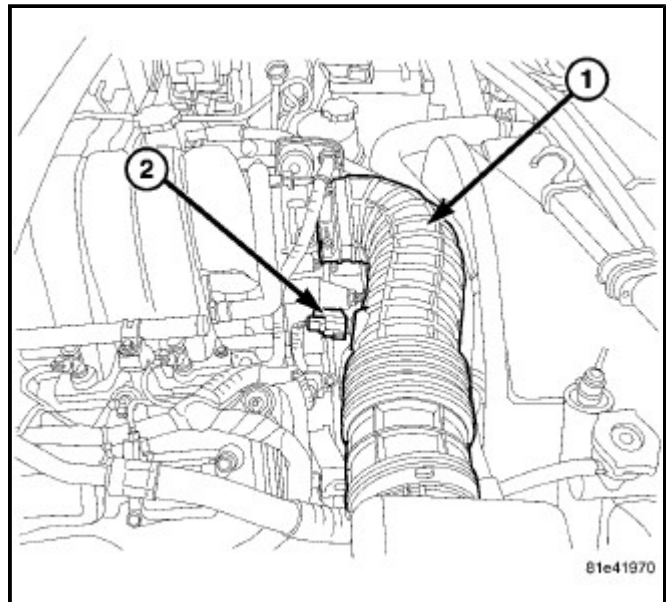

6. Disconnect the manifold air pressure (MAP) sensor connector (1) located at the back of the intake manifold.
7. Disconnect the throttle body electrical connector.

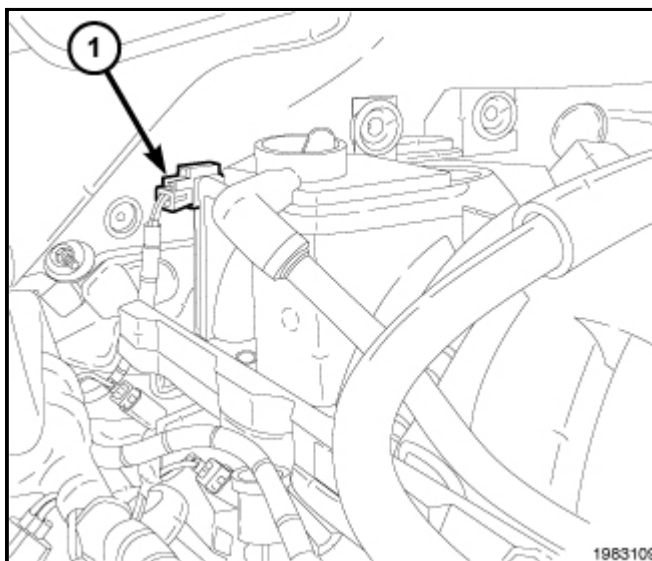

8. Disconnect the brake booster vacuum hose, vapor purge vacuum hose (2), and the make up air (MUA) hose (1) to the Intake manifold.

**NOTE:** The factory fuel injection wiring harness is numerically tagged (INJ 1, INJ 2, etc.) for injector position identification. If the harness is not tagged, note wiring location before removal.

9. Disconnect the fuel injector electrical connectors.

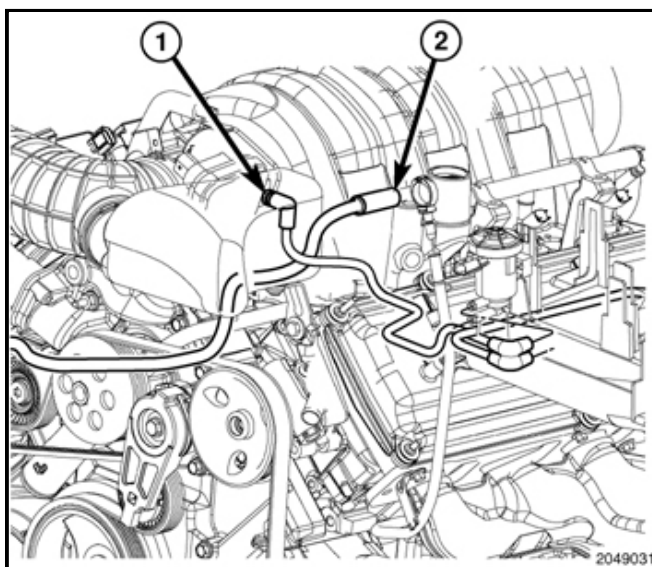

10. Using the sequence shown, remove the intake manifold retaining fasteners.
11. Remove the intake manifold and throttle body as an assembly.

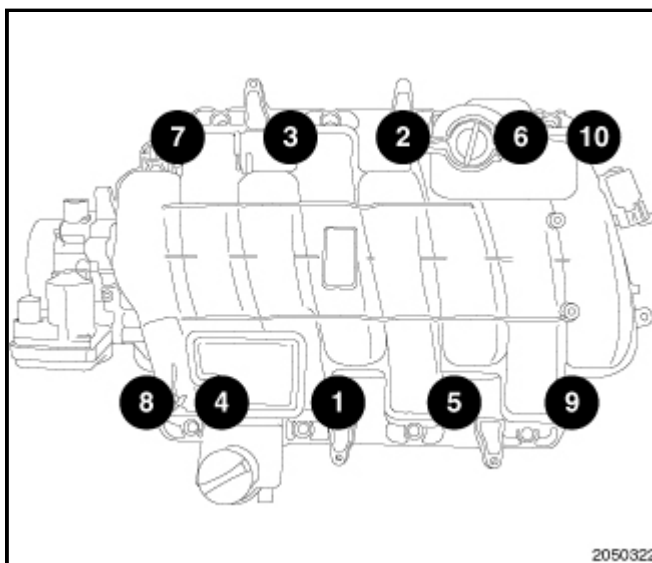

## 14 - Fuel System / Fuel Delivery, Gas / FITTING, Quick Connect/Standard Procedure

# STANDARD PROCEDURE - QUICK-CONNECT FITTINGS

Different types of quick-connect fittings are used to attach the various fuel system components, lines and tubes. Some quick-connect fittings require the use of a special tool for disconnection and removal.

These are the quick-connect fittings:

- Redundant Latch Single Button Type Fitting
- Single Button Type Fitting
- Pinch Type Fitting
- Single Tab Type Fitting
- Two Tab Type Fitting
- Plastic Retainer Ring Type Fitting
- Latch Clip Type 1 Fitting
- Latch Clip Type 2 Fitting
- Wing Type Fitting

## DISCONNECTING

**WARNING:** The fuel system is under a constant pressure (even with engine off). Before servicing any fuel system hose, fitting or line, fuel system pressure must be released. ([Refer to 14 - Fuel System/Fuel Delivery - Standard Procedure](#))

**CAUTION:** Before separating a Quick-Connect fitting, pay attention to what type of fitting is being used ([Refer to 14 - Fuel System/Fuel Delivery/FITTING, Quick Connect - Standard Procedure](#)). This will prevent unnecessary fitting or fitting latch breakage.

**CAUTION:** The interior components (O-rings, clips) of quick-connect fittings are not serviced separately, but new plastic spacers and latches are available for some types. If service parts are not available, do not attempt to repair the damaged fitting or fuel line (tube). If repair is necessary, replace the complete fuel line (tube) assembly.

## Redundant Latch Single Button Type Fitting:

This type of quick-connect fitting is equipped with a redundant latch (2) and a single push button (1) that releases two internal latches located in the quick-connect fitting. Special tools are not required for removal.



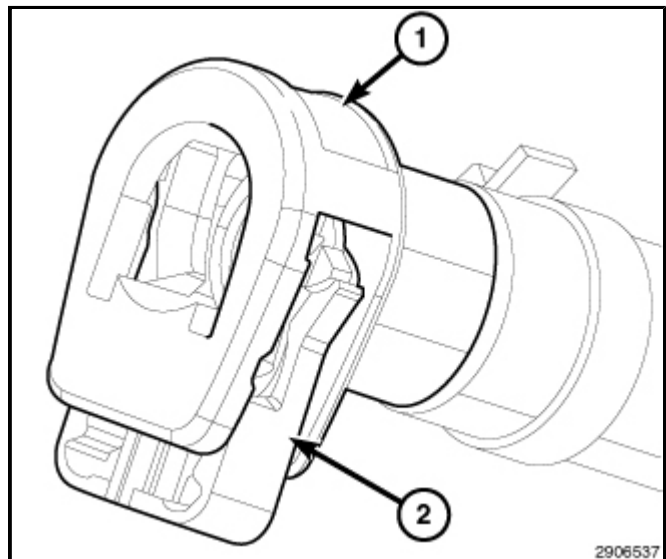

**CAUTION:** Do not pry or pull up on the push button as damage to the latches of the quick-connect fitting will occur.

1. Pull the redundant latch (2) out away from the quick-connect fitting.
2. Press on the push button with your thumb, release the internal latches (1) and remove the quick-connect fitting from the fuel system component.

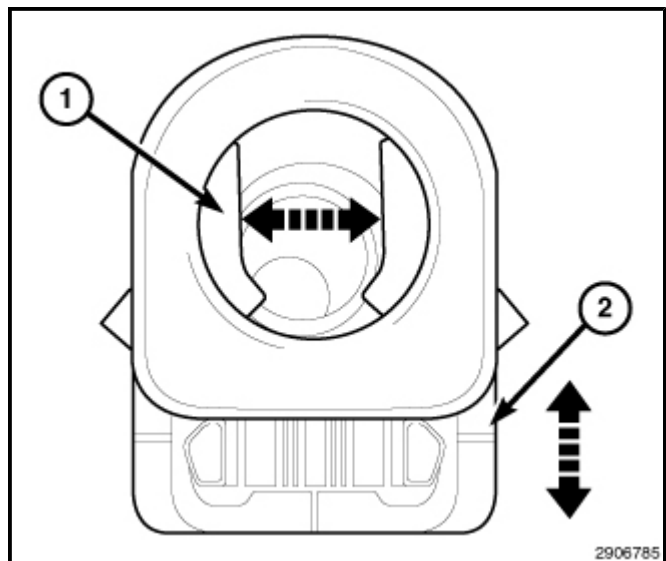

### Single Button Type Fitting:

**CAUTION:** Do not pry or pull up on the push button as damage to the latches of the quick-connect fitting will occur.

This type of quick-connect fitting is equipped with a single push button (2) that releases two internal latches located in the quick-connect fitting. Special tools are not required for removal.

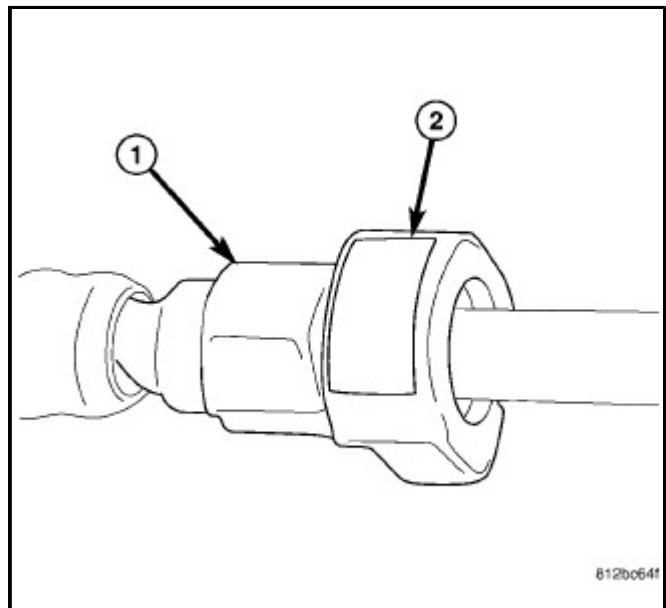

1. Press on the push button with your thumb, release the internal latches (1).
2. Remove the quick-connect fitting from the fuel system component.

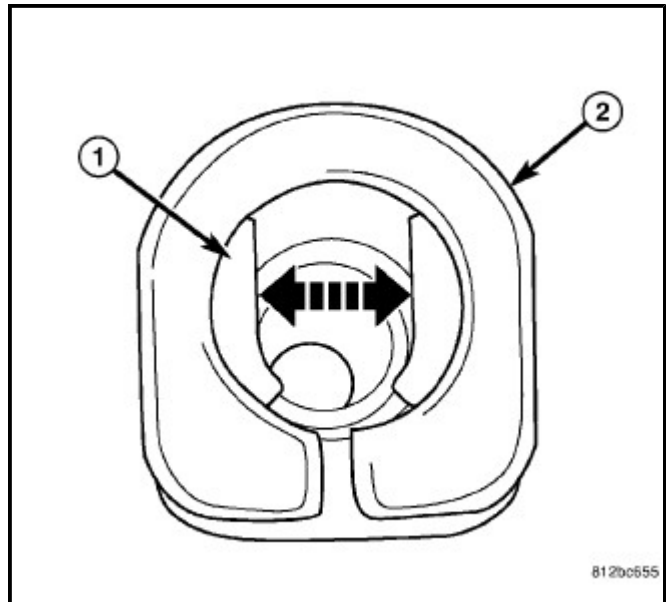

## 2 Button Type Fitting

This type of quick-connect fitting (1) is equipped with two push buttons (2) that releases two internal latches located in the quick-connect fitting. Special tools are not required for removal.

1. Press on both push buttons with your thumb, release the internal latches.
2. While holding the two push buttons simultaneously, remove the quick-connect fitting from the fuel system component.



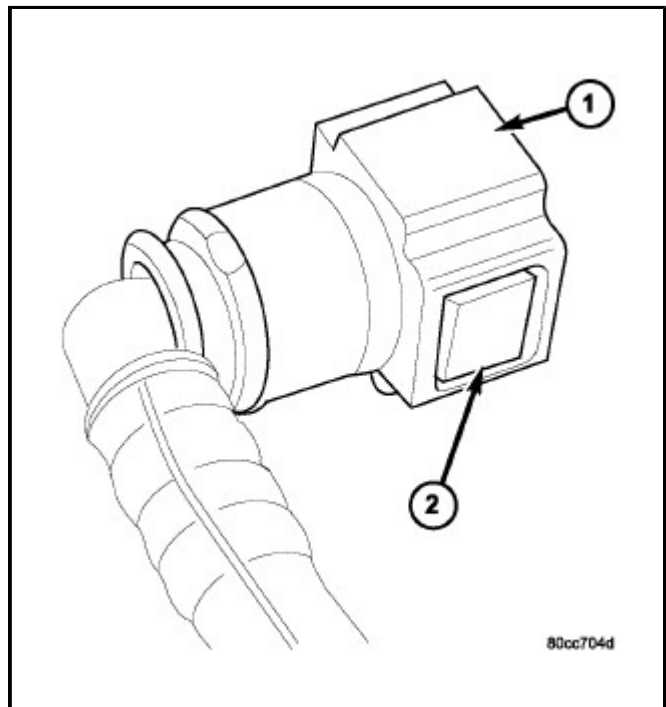

## Pinch Type Fitting

This type of quick-connect fitting (1) is equipped with two finger tabs (2). Special tools are not required for removal.

1. Pinch both tabs (2) together and release the quick-connect fitting.
2. Remove the quick-connect fitting from the fuel system component.

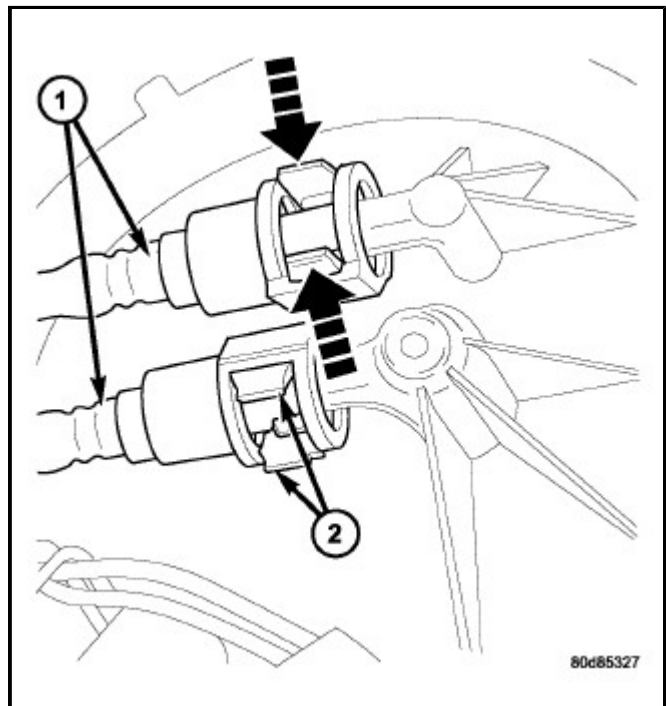

## Single Tab Type Fitting

This type of quick-connect fitting (3) is equipped with a single pull tab (1). The tab is removable. After tab is removed the quick-connect fitting can be separated from the fuel system component. Special tools are not

required for removal.

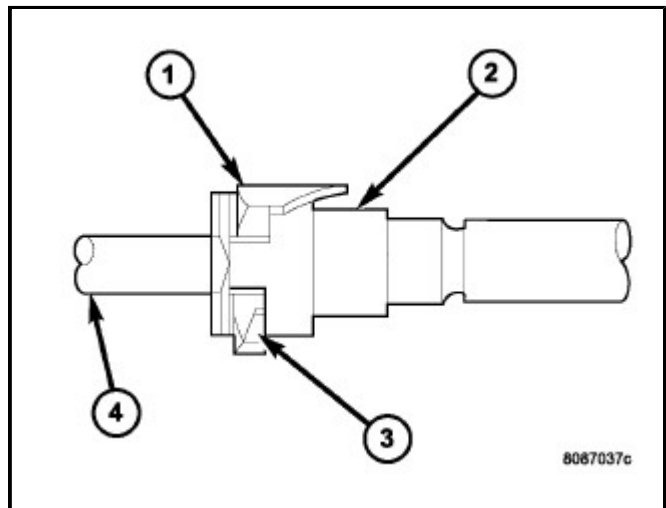

1. Press release tab on side of fitting to release pull tab (1). **If release tab is not pressed prior to releasing pull tab, pull tab will be damaged.**
2. While pressing the release tab on the side of the quick-connect fitting use a screwdriver (2) to pry up the pull tab.
3. Raise the pull tab until it separates from the quick-connect fitting.
4. Remove the quick-connect fitting from the fuel system component.

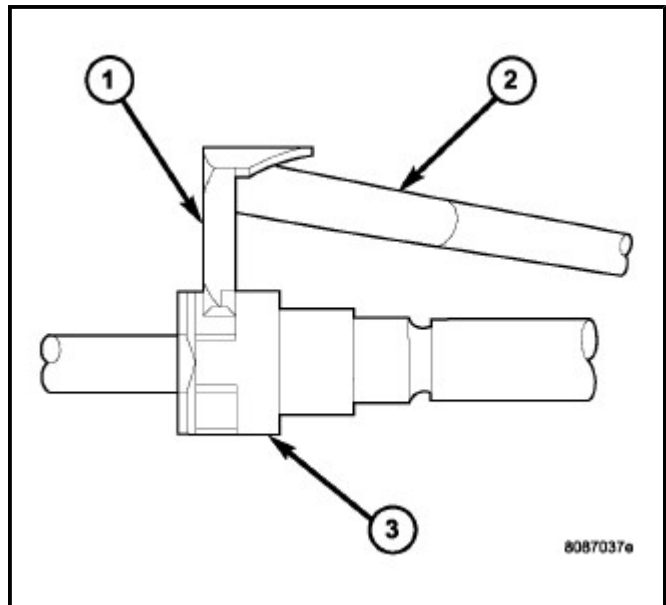

## Two Tab Type Fitting

This type of quick-connect fitting (2) is equipped with tabs located on both sides of the fitting (1). These tabs are integral to the fuel system component. The plastic tabs will remain on the component being serviced after the quick-connect fitting is removed. The O-ring and spacer will remain in the quick-connect fitting. Special tools are not required for removal.

1. Squeeze the plastic tabs (1) against the sides of component being serviced with your fingers.
2. Remove the quick-connect fitting from the fuel system component.

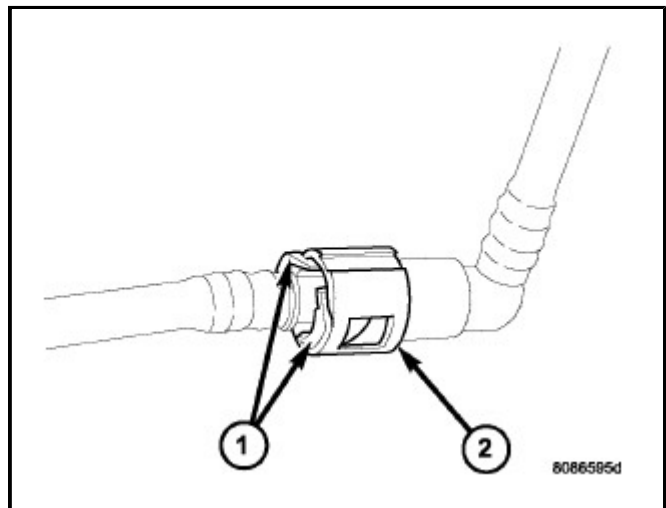

## Plastic Retainer Ring Type Fitting

This type of fitting can be identified by the use of a round plastic retainer ring (4) usually black in color. Special tools are not required for removal.

**NOTE:** The round plastic retainer ring must be pressed squarely into the quick-connect fitting body. If this retainer is cocked during removal it will be difficult to disconnect the quick-connect fitting. Use an open-end wrench on the shoulder of the plastic retainer ring to aid in disconnection.

1. Firmly push the quick-connect fitting (5) towards the component being serviced while firmly pushing the round plastic retainer ring into the quick-connect fitting (6). With the round plastic ring depressed, remove the quick-connect fitting from the fuel system component.
2. After removal the plastic retainer ring will remain with the quick-connect fitting.

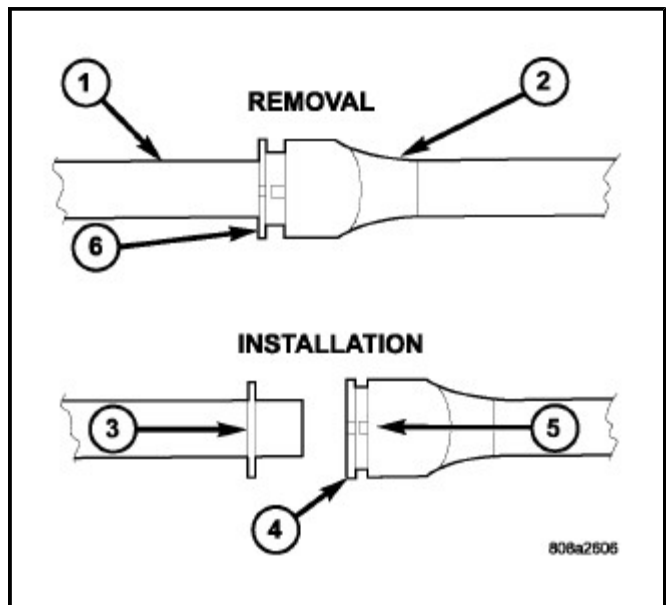

## Latch Clip Type 1 Fitting

Depending on vehicle model and engine, 2 different types of safety latch clips are used. One is tethered (1) to fuel line and the other is not. A special tool will be necessary to disconnect the fuel line after latch clip is removed. The latch clip may be used on certain fuel line and fuel rail connections or to join fuel lines together.

1. Pry up on the latch clip (4) with a screwdriver (3).
2. Slide the latch clip away from the quick-connect

fitting while lifting the screwdriver and position aside.

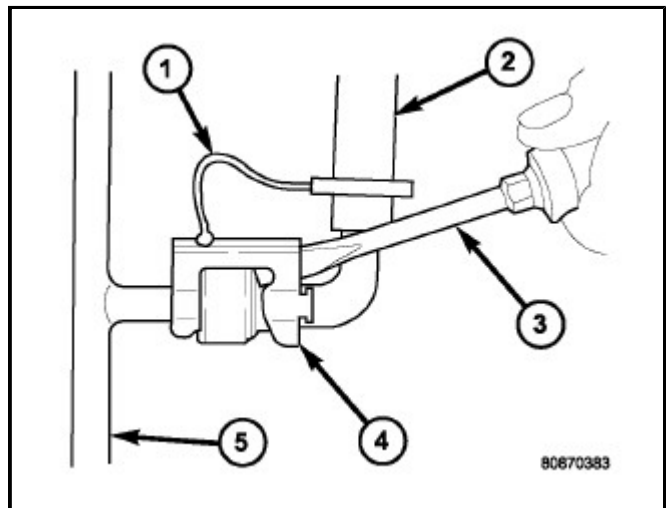

3. Insert the commercially available fuel line removal tool (1) into the quick-connect fitting and release the internal latches.

**NOTE:** After removal the internal latches will remain in the quick-connect fitting.

4. With the commercially available fuel line removal tool (1) still inserted, remove the quick-connect fitting from the fuel system component.

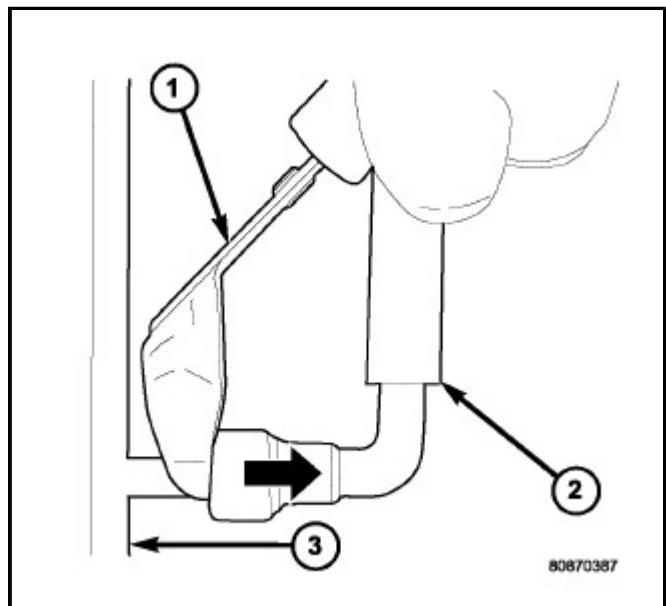

## Latch Clip Type 2 Fitting

Depending on vehicle model and engine, 2 different types of safety latch clips are used. One is tethered to the fuel line and the other is not. A special tool will be necessary to disconnect the fuel line after the latch clip is removed. The latch clip may be used on certain fuel line and fuel rail connections or to join fuel lines together.

1. Unlatch the small arms on the end of clip, swing away and separate from the fuel system component.
2. Slide the latch clip away from the quick-connect fitting while lifting with a screwdriver and position aside.

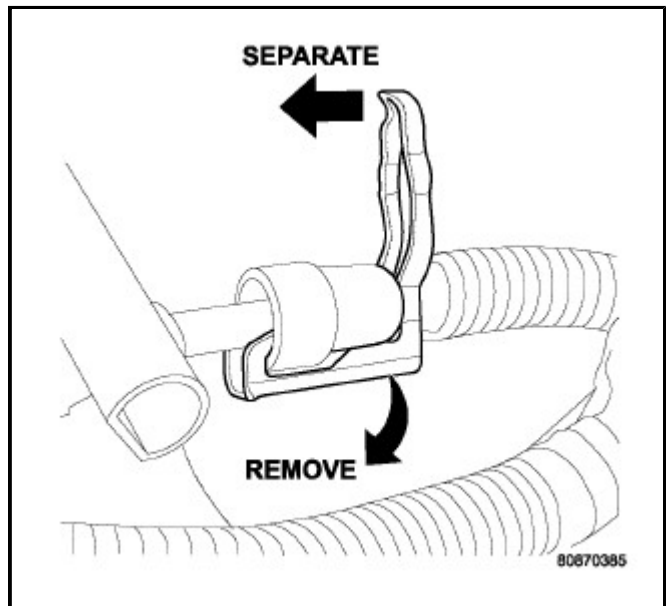

3. Insert the commercially available fuel line removal tool (1) into the quick-connect fitting and release the internal latches.

**NOTE:** After removal the internal latches will remain in the quick-connect fitting.

4. With the commercially available fuel line removal tool (1) inserted, remove the quick-connect fitting from the fuel system component.

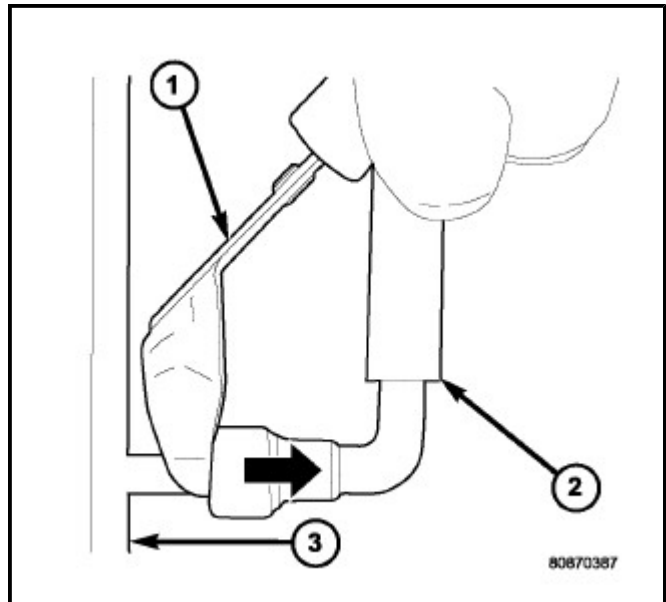

## Wing Type Fitting

The wing type fitting is used on fuel system and emission components. The wing type fitting is most commonly used on the EVAP canister (3). Special tools are not required for removal.

1. Using two fingers, press both wings (2) and release the locking tabs.

**NOTE:** After removal the locking tabs will remain with the quick-connect fitting.

2. While holding the wings, remove the quick-connect fitting from the fuel system component.

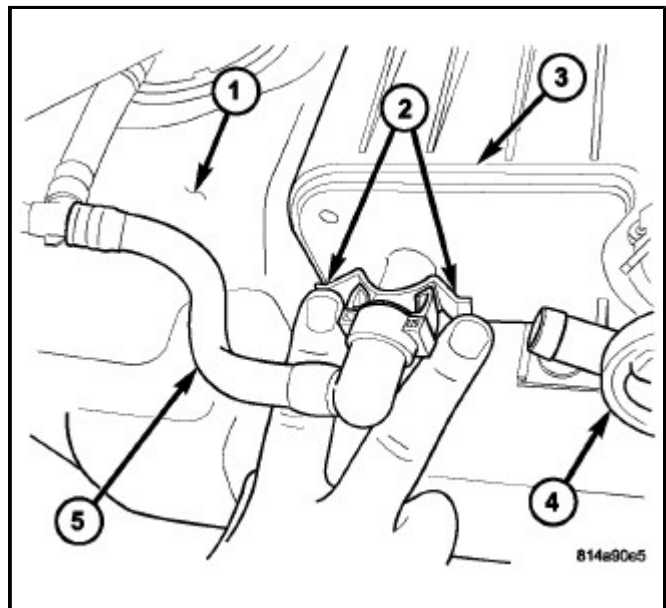

## CONNECTING

1. Inspect the quick-connect fitting body and fuel system components for damage. Replace as necessary.
2. Prior to connecting any quick-connect fitting to components, check condition of fitting and components. Clean parts with a lint-free cloth. Lubricate with clean engine oil.
3. Insert the quick-connect fitting onto the fuel tube or fuel system component until the built-in stop on the fuel tube or component rests against the back of fitting.
4. Continue pushing until a click is felt.
5. If Equipped:
  - **Redundant Latch Single Button Type Fitting:** Push redundant latch until it locks into position in the quick-connect fitting.
  - **Single Tab Type Fitting:** Push new tab down until it locks into position in the quick-connect fitting.
  - **Latch Clip Type Fitting:** Install latch clip (snaps into position). **If latch clip will not snap into position, this indicates the quick-connect fitting is not properly installed onto fuel system component, recheck the connection.**
6. Verify a locked condition by firmly pulling on the quick-connect fitting connection of the fuel system component.

## 8F - Engine Systems / Starting / STARTER/Removal

### 5.7L/6.1L

1. Disconnect and isolate negative battery cable.
2. Raise and support vehicle.
3. Note: If equipped with 4WD and certain transmissions, a support bracket is used between front axle and side of transmission. Remove 2 support bracket bolts at transmission. Pry support bracket slightly to gain access to lower starter mounting bolt.
4. Remove two mounting bolts (2).
5. Move starter motor towards front of vehicle far enough for nose of starter pinion housing to clear housing. Always support starter motor (1) during this process, do not let starter motor hang from wire harness.
6. Tilt nose downwards and lower starter motor far enough to access and remove nut that secures battery positive cable wire harness connector eyelet to solenoid battery terminal stud. Do not let starter motor hang from wire harness.
7. Remove battery positive cable wire harness connector eyelet from solenoid battery terminal stud.
8. Disconnect battery positive cable wire harness connector from solenoid terminal connector receptacle.
9. Remove starter motor.

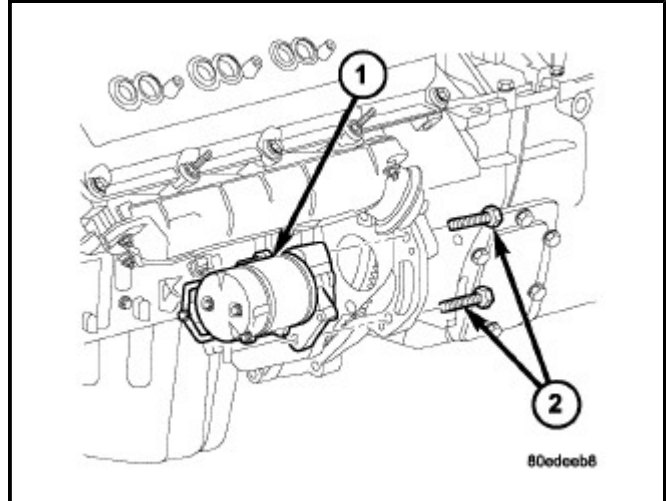





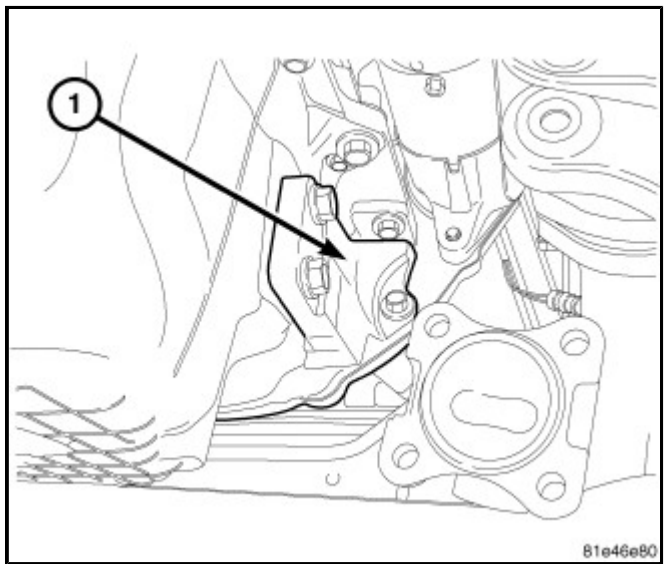

81e46e80

## 2009 - Engine, 6.1L/Installation

# INSTALLATION

1. Install Engine Lift Fixture [8984B](#) and [8984-UPD](#) .
2. Position the engine in the engine compartment.
3. Lower the engine into compartment and align engine with transmission.

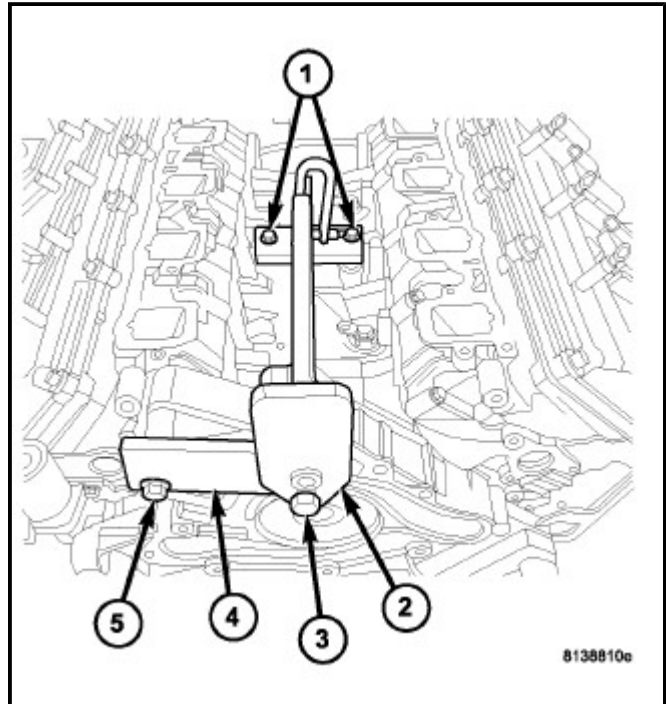

4. Mate engine (1) and transmission (3) and install two transmission to engine block mounting bolts (2) finger tight.

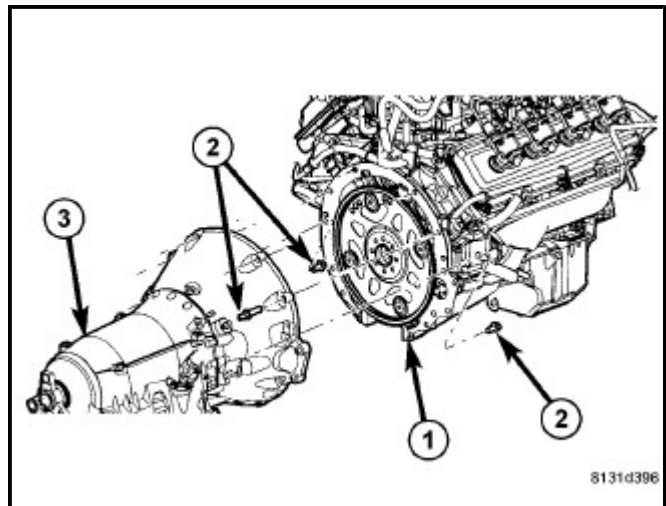

5. Lower engine assembly until the engine mounts (2) rests in frame perches (1).

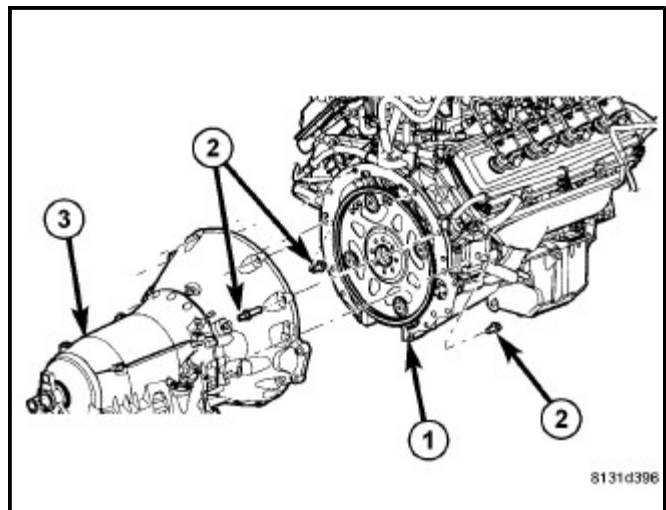
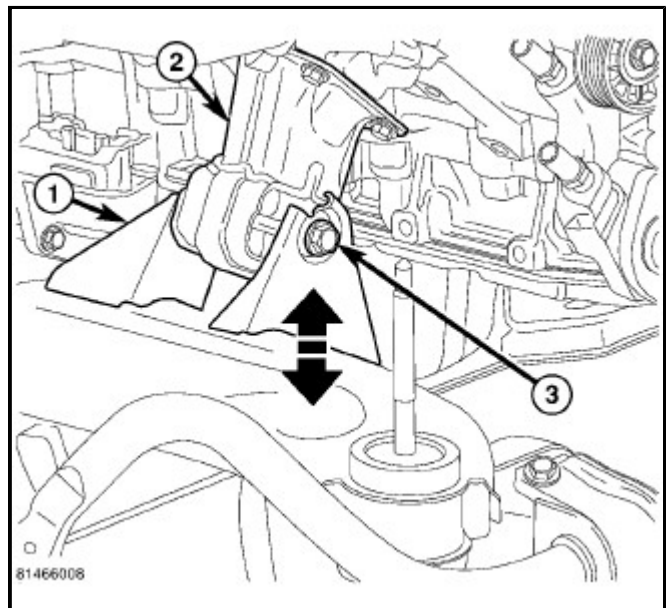

6. Install remaining transmission to engine block mounting bolts (2) and the oil pan to transmission bolts (1) and tighten.

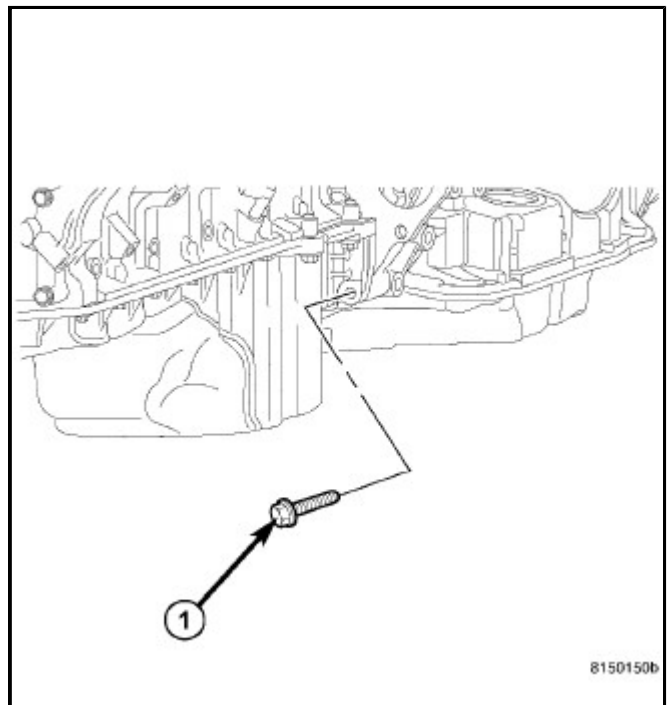

7. Install and tighten engine mount to frame bolts (3) and nuts.

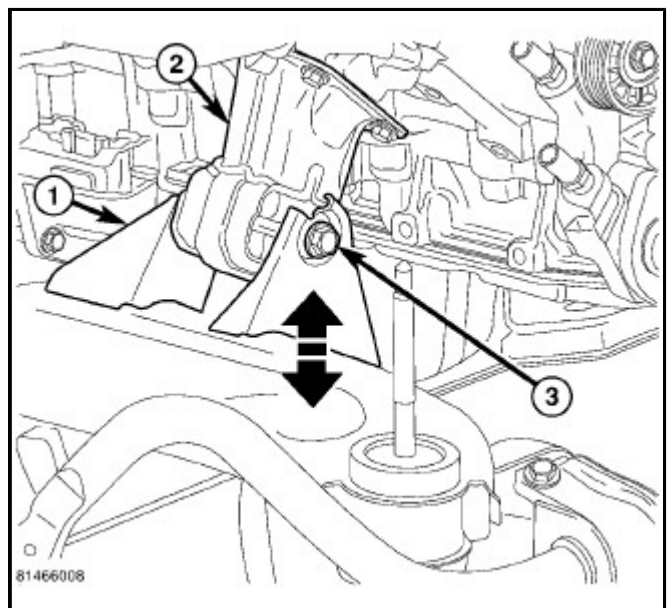

8. Install drive plate to torque converter bolts (1).
9. Install the structural dust cover (1).

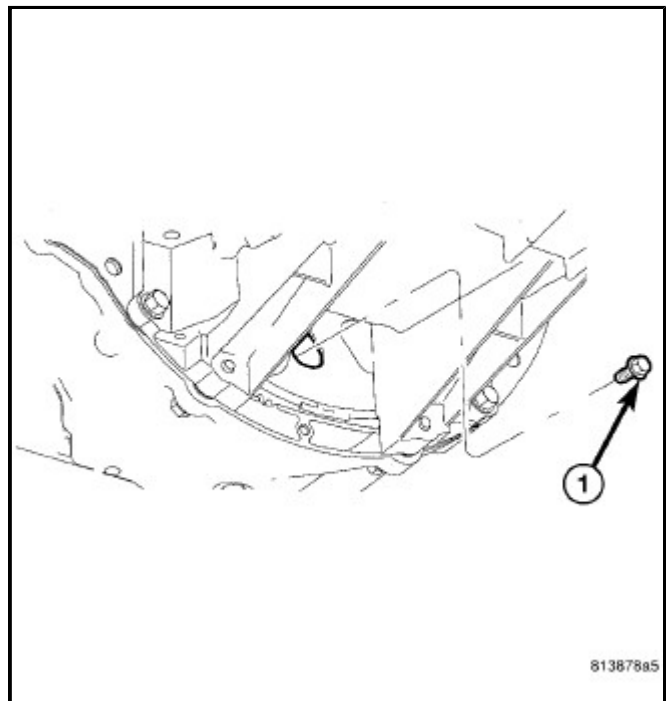

10. Install the starter (1) and connect the starter wires.  
[\(Refer to 08 - Electrical/8F - Engine Systems/Starting/STARTER - Installation\)](#)
11. Install the exhaust pipe to manifold.
12. Lower the vehicle.

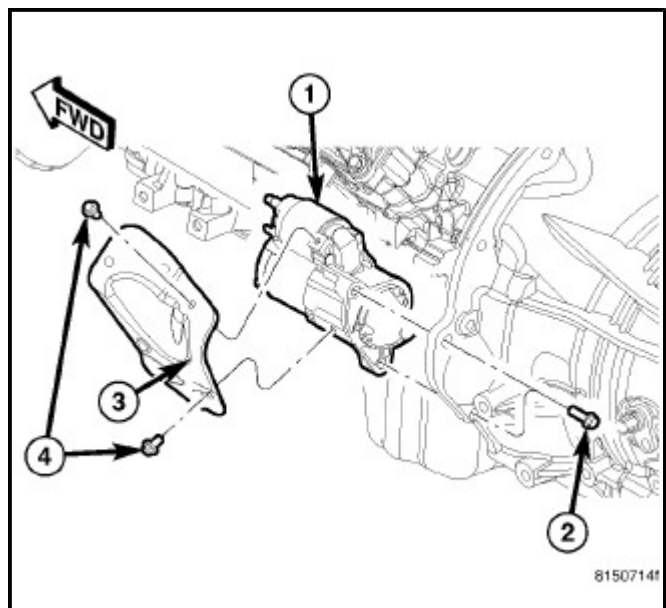

13. Remove Engine Lift Fixture [8984B](#) (2), and Adapter [8984-UPD](#) .

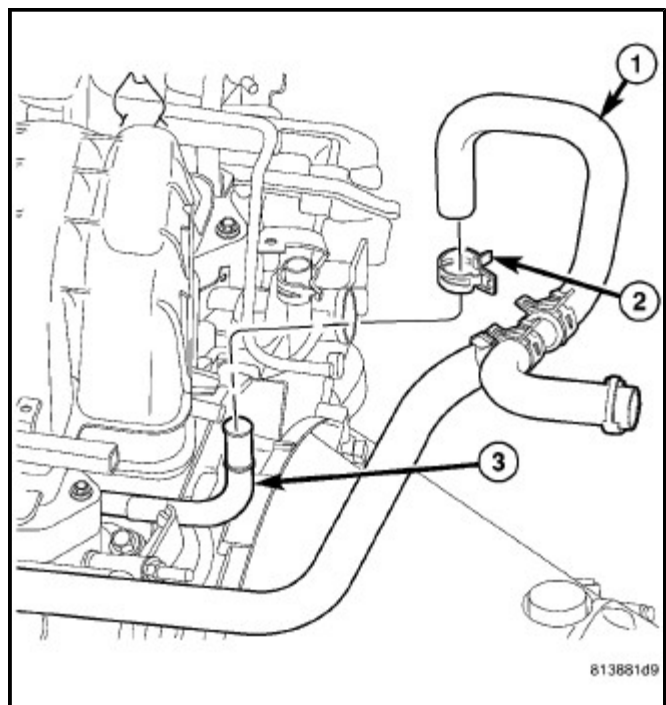
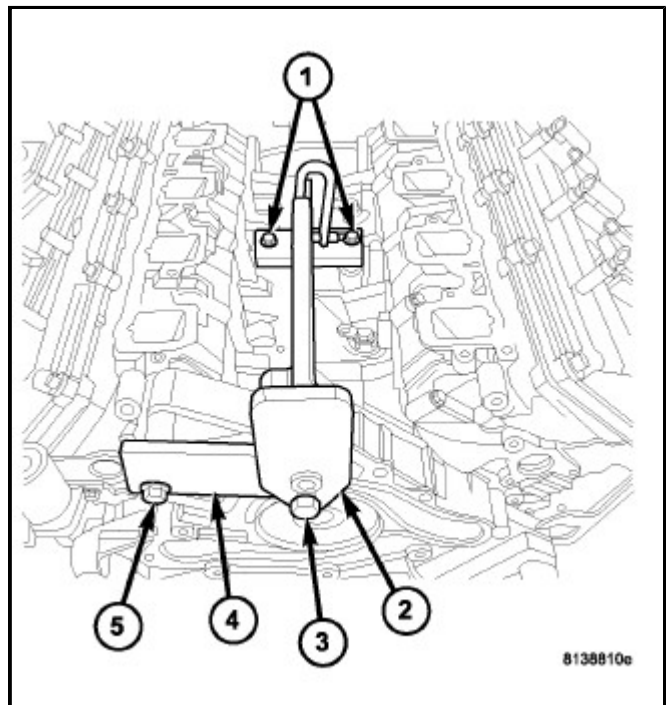

14. Connect the fuel supply line. ([Refer to 14 - Fuel System/Fuel Delivery/FITTING, Quick Connect - Standard Procedure](#))
15. Reinstall the power steering pump.
16. Connect the heater hoses (1).

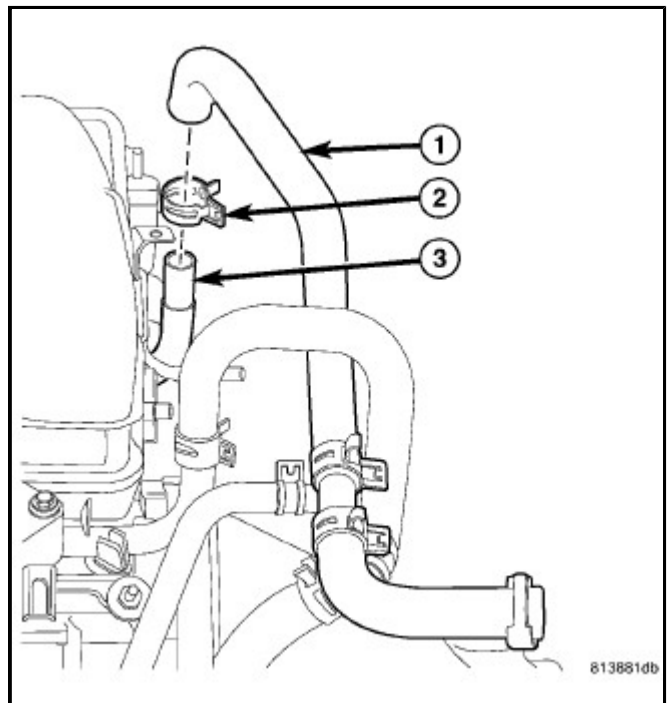

17. Reconnect the ground wires to the rear of each cylinder head.
18. Install the intake manifold. ([Refer to 09 - Engine/Manifolds/MANIFOLD, Intake - Installation](#))
19. Install the generator (2), and wire connections. ([Refer to 08 - Electrical/8F - Engine Systems/Charging/GENERATOR - Installation](#))

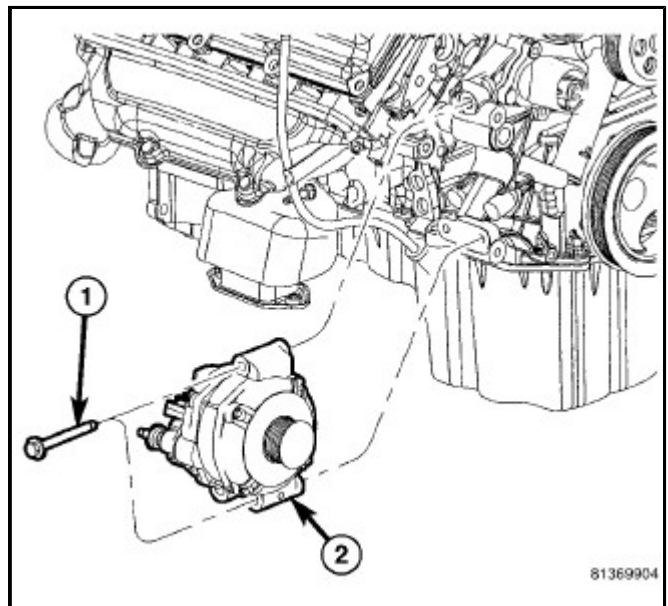

20. Install the A/C Compressor (3). ([Refer to 24 - Heating and Air Conditioning/Plumbing/COMPRESSOR, A/C - Installation](#))

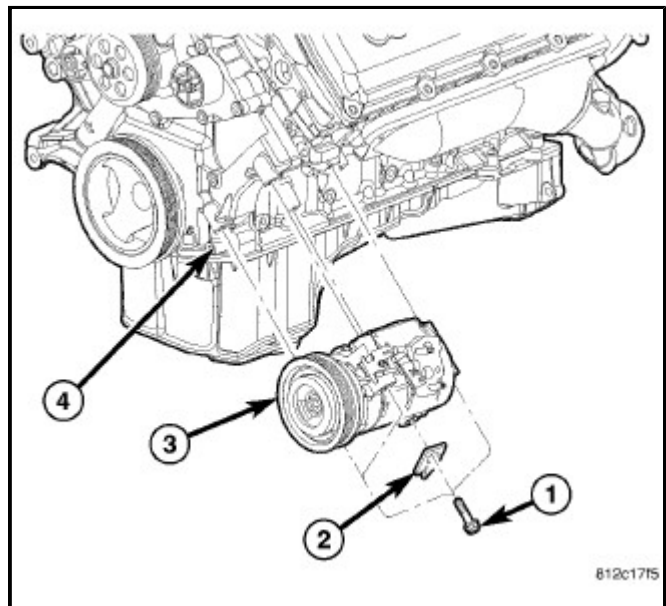

21. Install the accessory drive belt. ([Refer to 07 - Cooling/Accessory Drive/BELT, Serpentine - Installation](#))
22. Install the radiator fan shroud. ([Refer to 07 - Cooling/Engine/FAN, Cooling - Installation](#))
23. Connect the radiator lower hose.
24. Connect the transmission oil cooler lines to the radiator.
25. Connect the radiator upper hose.

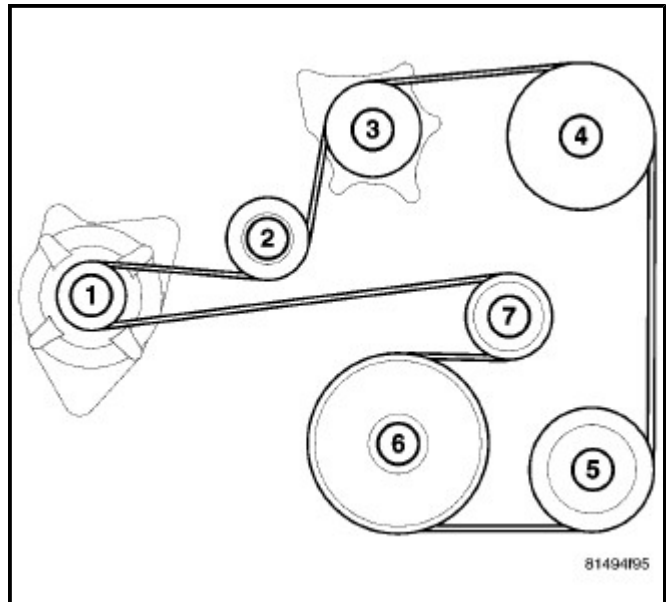

26. Install the air cleaner resonator and duct work.
27. Add engine oil to crankcase. ([Refer to 04 - Vehicle Quick Reference/Capacities and Recommended Fluids - Specifications](#))
28. Fill the cooling system. ([Refer to 07 - Cooling - Standard Procedure](#))
29. Install the engine cover (1).



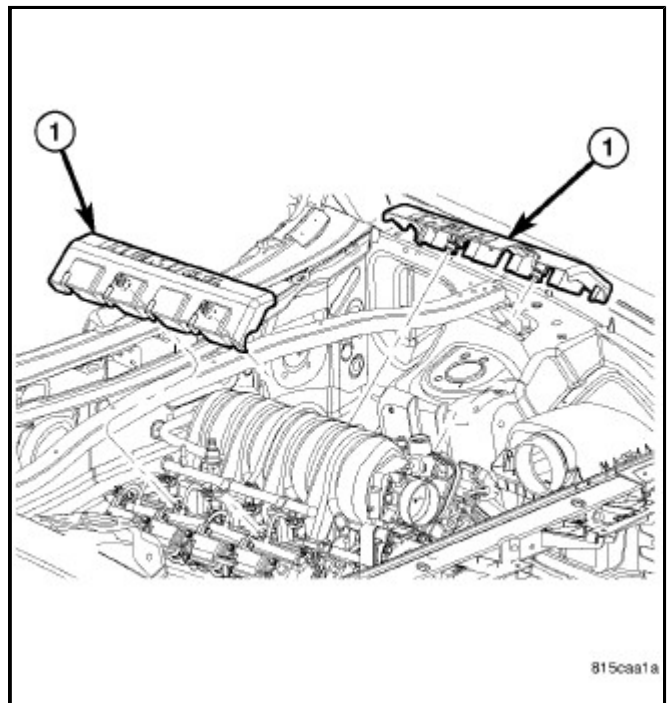

30. Install the strut tower support (1).
31. Connect battery negative cable.
32. Start engine and inspect for leaks.
33. Road test vehicle.

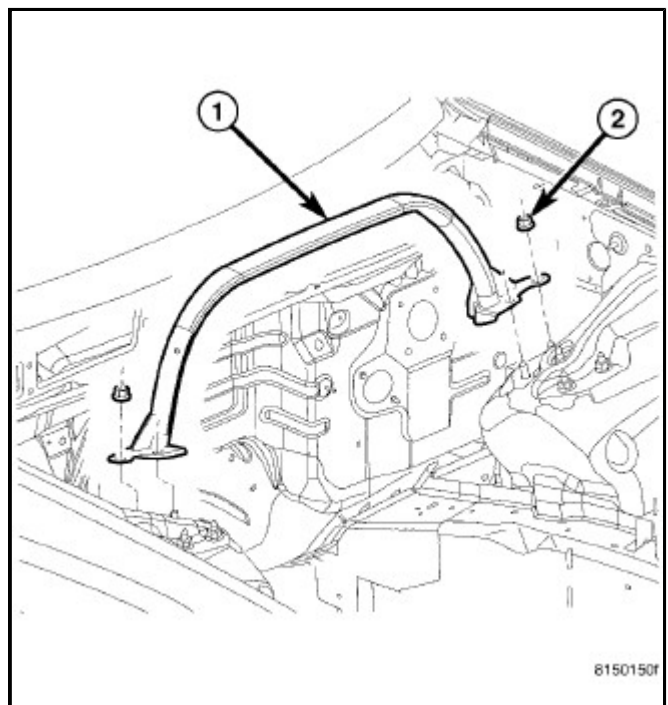

## Expanded details section

### 8F - Engine Systems / Starting / STARTER/Installation

#### 5.7L/6.1L

1. Connect solenoid wire to starter motor (snaps on).
2. Position battery cable to solenoid stud. Install and tighten battery cable eyelet nut. Torque nut to 25 N·m (19 ft. lbs.). Do not allow starter motor to hang from wire harness.
3. Position starter motor (1) to engine.
4. If equipped with automatic transmission, slide cooler tube bracket into position.
5. Install and tighten both mounting bolts (2). Torque bolts to 68 N·m (50 ft. lbs.).
6. Lower vehicle.
7. Connect negative battery cable.

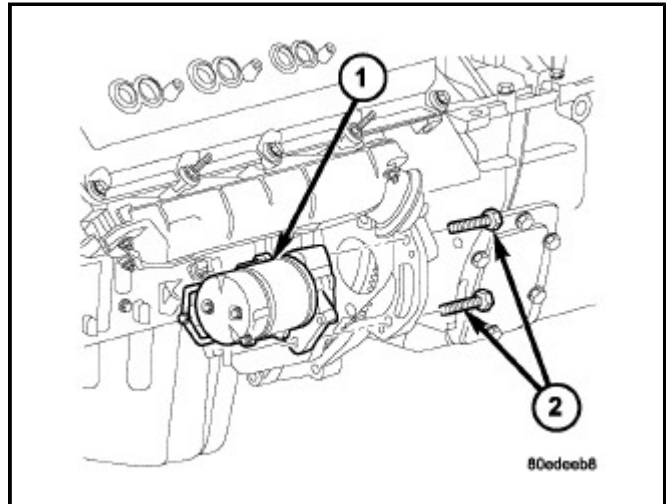

## 09 - Engine, 6.1L / Manifolds / MANIFOLD, Intake/Installation

# INSTALLATION

1. Install the intake manifold seals.
2. Carefully position the intake manifold without disturbing the seals.
3. Apply Mopar® Lock & Seal Adhesive to the intake manifold retaining bolts.
4. Using the sequence shown, install the intake manifold retaining bolts and tighten to 12 N·m (9 ft. lbs).

**NOTE:** The factory fuel injection wiring harness is numerically tagged (INJ 1, INJ 2, etc.) for injector position identification. If the harness was not tagged, note the wiring location previously marked before removal.

5. Connect the fuel injector electrical connectors.

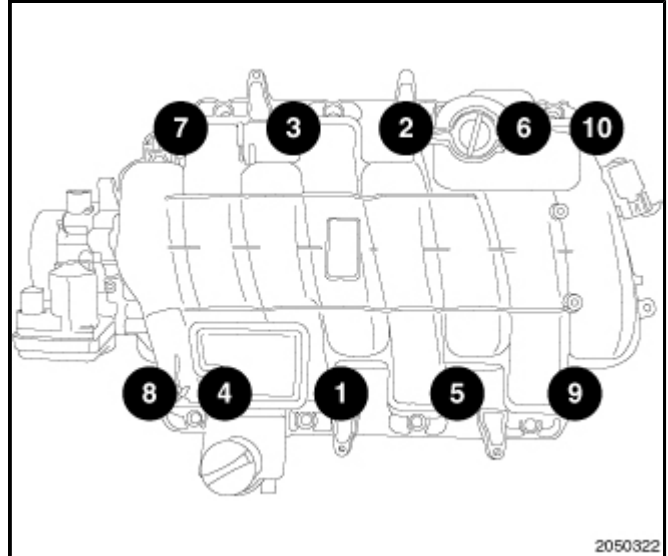

6. Connect the fuel supply line quick connect fitting (1) at the fuel rail and install the safety retainer clip.

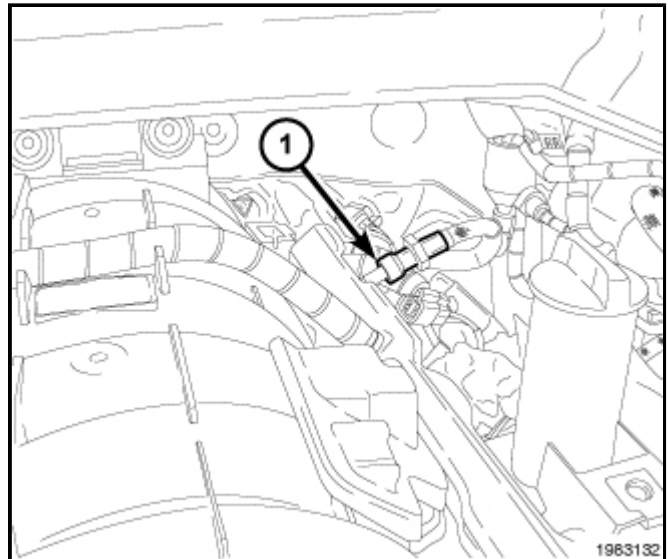

7. Connect the brake booster vacuum hose, vapor purge vacuum hose (2), and the make up air (MUA) hose (1).

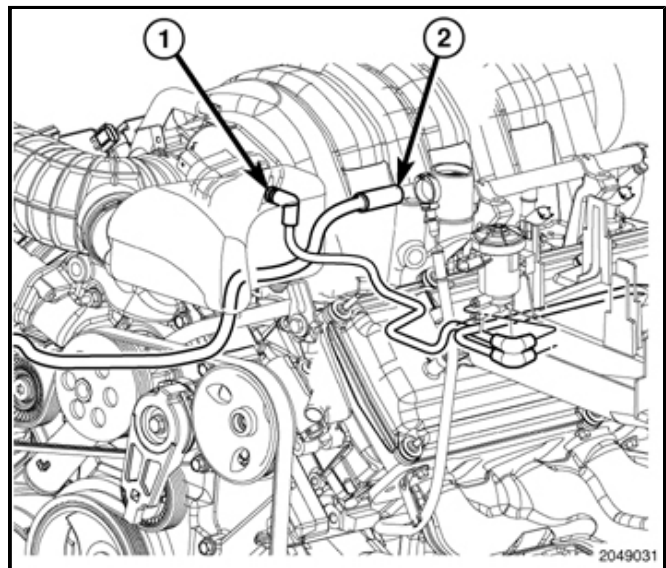

8. Connect the manifold air pressure (MAP) sensor connector (1) located at the back of the intake manifold.
9. Connect the throttle body electrical connector.

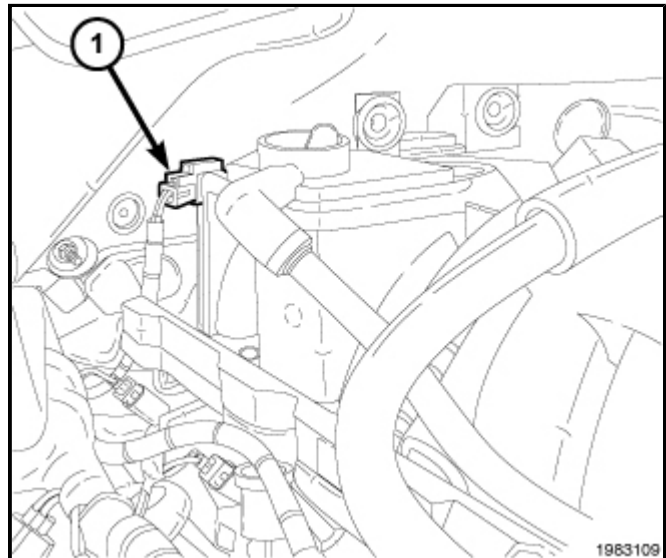

10. Install the clean air tube (1).
11. Connect the intake air temperature (IAT) sensor connector (2).

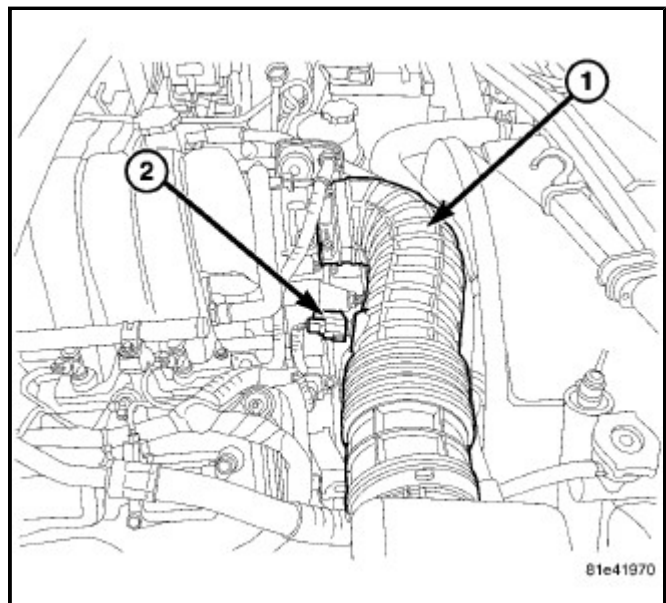

12. Install the engine covers (1), they snap on the fuel rail ball studs (2).
13. Connect the negative battery cable.

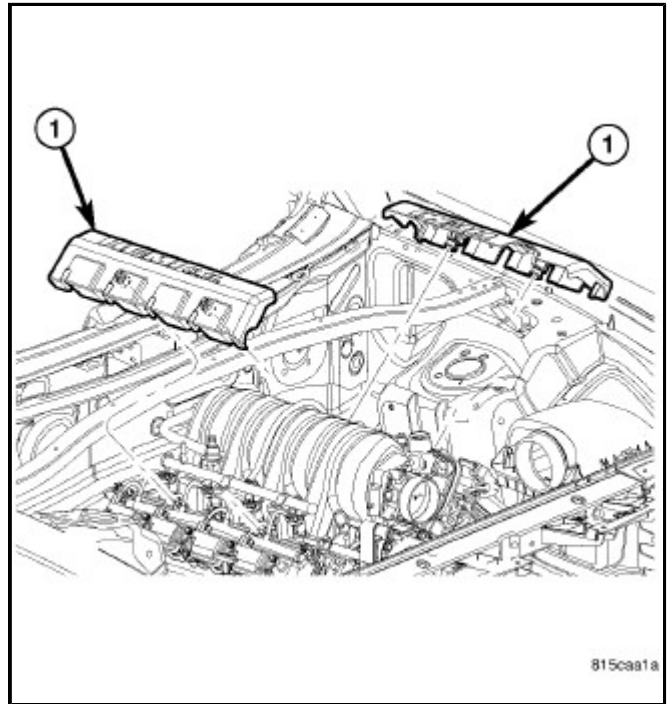

## 24 - Heating and Air Conditioning / Plumbing / COMPRESSOR, A/C/Installation

### 5.7L/6.1L ENGINES

**CAUTION:** If the A/C compressor is being replaced, be certain to adjust the refrigerant system oil level ([Refer to 24 - Heating and Air Conditioning/Plumbing/OIL, Refrigerant - Standard Procedure](#)). Failure to properly adjust the refrigerant oil level will prevent the A/C system from operating as designed and can cause serious A/C compressor damage.

**NOTE:** The A/C receiver/drier must be replaced if an internal failure of the A/C compressor has occurred ([Refer to 24 - Heating and Air Conditioning/Plumbing/DRIER, A/C Receiver - Removal](#)).

**NOTE:** When replacing multiple A/C system components, see the Refrigerant Oil Capacities chart to determine how much oil should be removed from the new A/C compressor ([Refer to 24 - Heating and Air Conditioning/Plumbing/OIL, Refrigerant - Standard Procedure](#)).

**NOTE:** Replacement of the refrigerant line O-ring seals and gaskets is required anytime a refrigerant line is disconnected. Failure to replace the rubber O-ring seals and metal gaskets may result in a refrigerant system leak.

1. If the A/C compressor (5) is being replaced, the refrigerant oil in the old compressor must be first drained and measured. Then the oil in the new A/C compressor must be drained. Finally, the new compressor must be refilled with the same amount of new refrigerant oil that was drained out of the old compressor. When replacing multiple A/C system components, see the Refrigerant Oil Capacities chart to determine how much oil should be added to the refrigerant system ([Refer to 24 - Heating and Air Conditioning/Plumbing/OIL, Refrigerant - Standard Procedure](#)). Use only refrigerant oil of the type recommended for the A/C compressor in the vehicle.
2. Position the A/C compressor into the engine compartment.
3. Install the three bolts (4) that secure the A/C compressor to the engine. Tighten the bolts to 55 N·m (41 ft. lbs.).
4. Connect the wire harness connector (3) to the A/C compressor.
5. Position the power steering pump (2) onto the engine.
6. Install the three bolts (1) that secure the power steering pump to the engine. Tighten the bolts securely.
7. Remove the tape or plugs from the opened refrigerant line fittings and the compressor ports.
8. Lubricate new dual-plane seals with clean

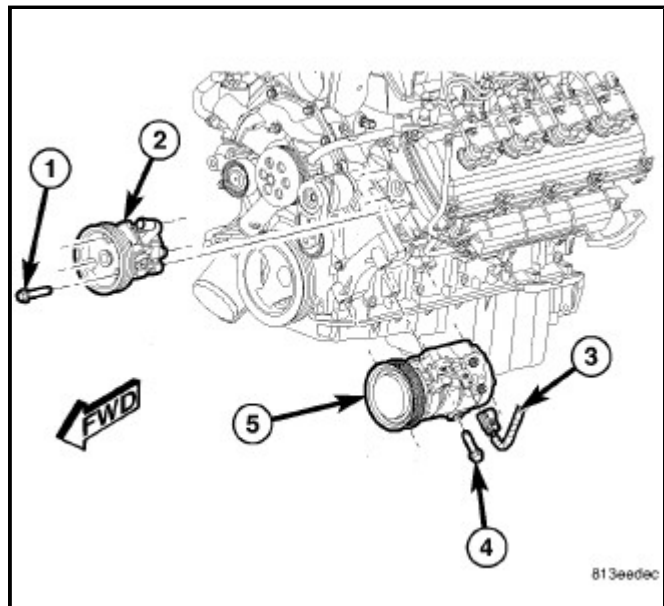

refrigerant oil and install them onto the refrigerant line fittings. Use only the specified seals as they are made of a special material for the R-134a system. Use only refrigerant oil of the type recommended for the A/C compressor in the vehicle.

9. Install the A/C suction line (3) and the A/C discharge line (1) onto the A/C compressor (4).
10. Install the nuts (2) that secure the refrigerant lines to the A/C compressor. Tighten the nuts to 20 N·m (15 ft. lbs.).
11. Install the accessory drive belt ([Refer to 07 - Cooling/Accessory Drive/BELT, Serpentine - Installation](#)).
12. Replace the A/C receiver/drier if the A/C compressor is being replaced due to an internal failure ([Refer to 24 - Heating and Air Conditioning/Plumbing/DRIER, A/C Receiver - Removal](#)).
13. Install the resonator onto the engine and the air cleaner housing ([Refer to 09 - Engine/Air Intake System - Installation](#)).
14. Reconnect the negative battery cable.
15. Evacuate and charge the refrigerant system ([Refer to 24 - Heating and Air Conditioning/Plumbing - Standard Procedure](#)).

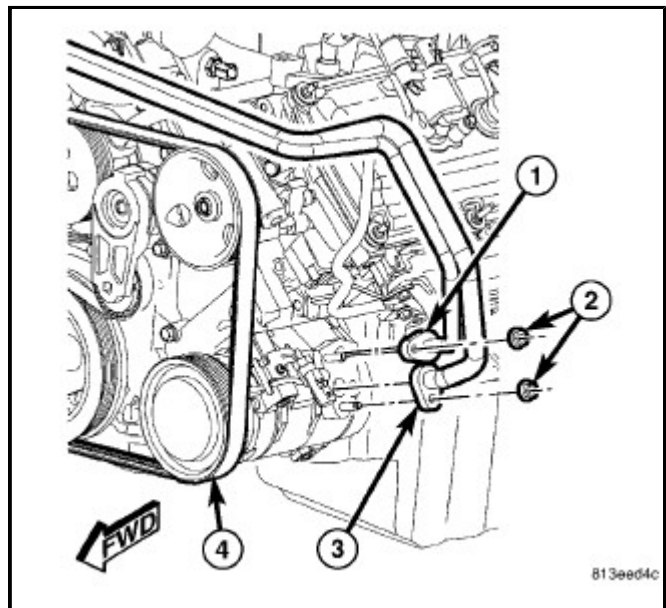

## 07 - Cooling / Accessory Drive / BELT, Serpentine/Installation

### 5.7L/6.1L ENGINE

**NOTE:** When installing accessory drive belt onto pulleys, make sure that belt is properly routed and all V-grooves make proper contact with pulleys.

1. Position the drive belt (2) over all pulleys except for the water pump pulley (7).
2. Rotate tensioner (8) **clockwise** and slip the belt (2) over the water pump pulley (7).
3. Gently release tensioner (8).
4. Install the air intake tube between intake manifold and air filter assembly.

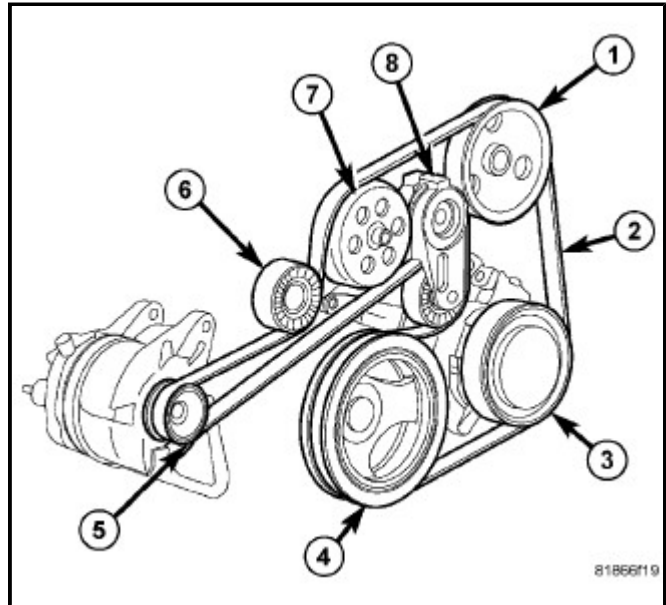



## 07 - Cooling/Engine/DRIVE, Fan/Installation

# INSTALLATION

1. Assemble fan blade to viscous fan drive. Tighten mounting bolts to 27 N·m (20 ft. lbs.) torque.

**NOTE:** The viscous fan and fan shroud must be installed as an assembly.

2. Gently lay viscous fan (2) into fan shroud.
3. Install the fan shroud to radiator mounting bolts, torque bolts to (6 N·M or 53 in·lbs).
4. Thread the fan and fan drive onto the water pump pulley, and tighten nut using special tool [6958](#) spanner wrench and [8346](#) adapters (1).
5. Install accessory drive belt ([Refer to 07 - Cooling/Accessory Drive/BELT, Serpentine - Installation](#)).

**CAUTION:** When installing a serpentine accessory drive belt, the belt **MUST** be routed correctly. If not, the engine may overheat due to the water pump rotating in the wrong direction. ([Refer to 07 - Cooling/Accessory Drive/BELT, Serpentine - Removal](#)) for correct belt routing.

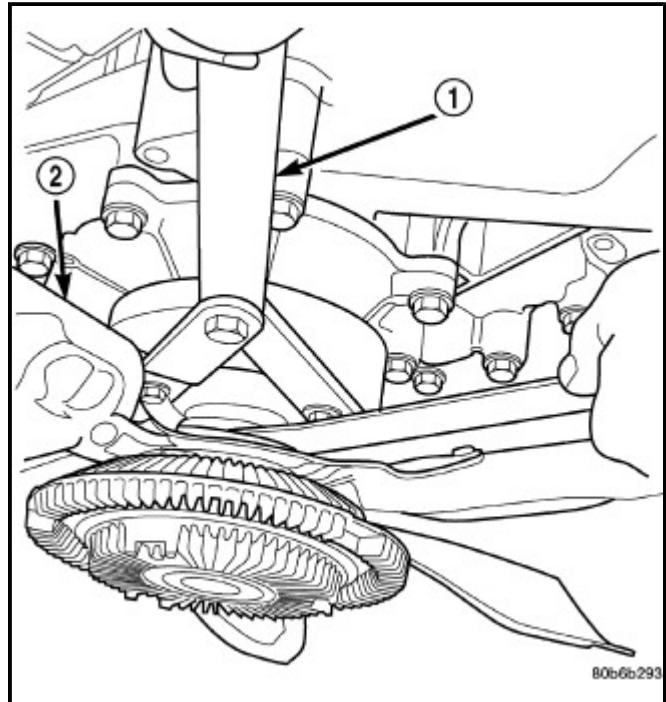

## 08 - Electrical/8F - Engine Systems/Charging/GENERATOR/Installation

### 6.1L

1. Position the generator (2) to the engine and install the two mounting bolts (1). Torque the bolts to 41 N·m (30 ft. lbs.).
2. Snap the field wire connector (3) into the rear of the generator.
3. Install the B+ terminal eyelet to the generator output stud. Tighten the mounting nut to 12 N·m (108 in. lbs.).

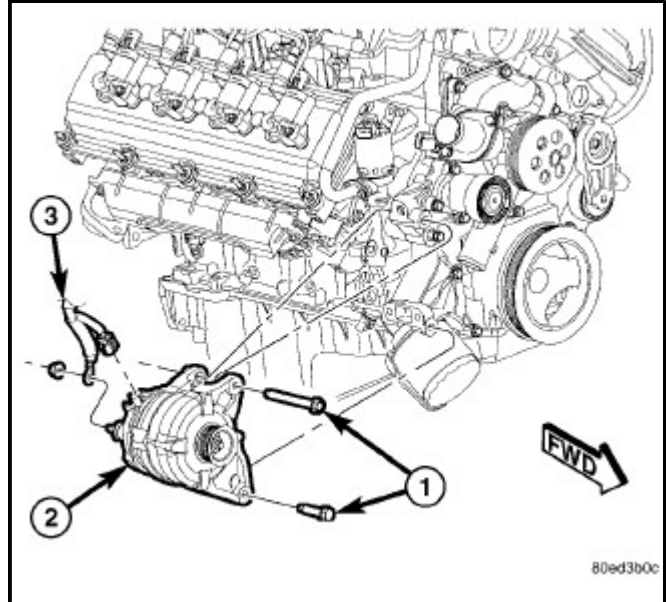

**CAUTION:** Never force a belt over a pulley rim using a screwdriver. The synthetic fiber of the belt can be damaged.

**CAUTION:** When installing a serpentine accessory drive belt, the belt must be routed correctly. The water pump may be rotating in the wrong direction if the belt is installed incorrectly, causing the engine to overheat. Refer to belt routing label in engine compartment, or Refer to the Belt Schematics in 7, Cooling System.

4. Install the serpentine belt ([Refer to 07 - Cooling/Accessory Drive/BELT, Serpentine - Installation](#)).
5. Install the air cleaner ([Refer to 09 - Engine/Air Intake System - Installation](#)).
6. Install the negative battery cable.

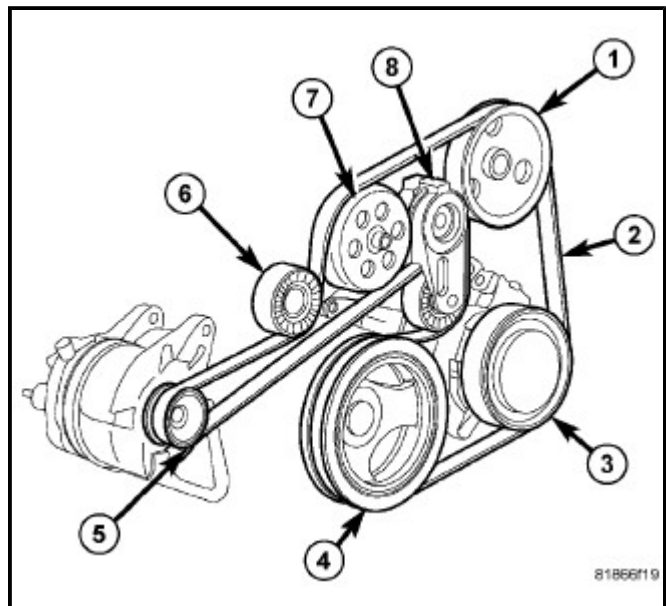

## 04 - Vehicle Quick Reference / Capacities and Recommended Fluids/Specifications

# SPECIFICATIONS

### ENGINE

Description	Type	Part Number	Capacities	
			U.S.	Metric
<b>Cooling System</b>				
◆ Engine Coolant (3.7L Engine)	MOPAR® Antifreeze/Coolant 5 Year/100,000 Mile Formula HOAT (Hybrid Organic Additive Technology)	1 Gallon - 05066386AA	9 Quarts	10 Liters
◆ Engine Coolant (4.7L and 5.7L Engines)	MOPAR® Antifreeze/Coolant 5 Year/100,000 Mile Formula HOAT (Hybrid Organic Additive Technology)	1 Gallon - 05066386AA	14.5 Quarts	13.7 Liters
◆ Engine Coolant (6.1L Engine)	MOPAR® Antifreeze/Coolant 5 Year/100,000 Mile Formula HOAT (Hybrid Organic Additive Technology)	1 Gallon - 05066386AA	14.8 Quarts	14 Liters
◆ Engine Coolant (3.0L Diesel Engine)	MOPAR® Antifreeze/Coolant 5 Year/100,000 Mile Formula HOAT (Hybrid Organic Additive Technology)	1 Gallon - 05066386AA	14 Quarts	13.2 Liters
<b>Engine Oil with Filter</b>				
◆◆◆◆ Engine Oil (3.7L Engine) Domestic and Export Non ACEA	MOPAR® API Certified SAE 5W-20 engine oil, meeting the requirements of Chrysler Material Standard MS-6395.	1 Quart - 04761872AC	5 Quarts	4.7 Liters
		5 Quarts - 04761851AD		
◆◆◆◆ Engine Oil (4.7L Engine) Domestic and Export Non ACEA	MOPAR® API Certified SAE 5W-20 engine oil, meeting the requirements of Chrysler Material Standard MS-6395.	1 Quart - 04761872AC	6 Quarts	5.7 Liters
		5 Quarts - 04761851AD		
◆◆◆◆ Engine Oil (5.7L Engine) Domestic and Export Non ACEA	MOPAR® API Certified SAE 5W-20 engine oil, meeting the requirements of Chrysler Material Standard MS-6395.	1 Quart - 04761872AC	7 Quarts	6.6 Liters
		5 Quarts - 04761851AD		
Engine Oil (6.1L Engine)	For best performance and maximum protection under all types of operating conditions, the manufacturer only recommends full synthetic engine oils that meet the American Petroleum Institute (API) categories of SM or SM/CF, and meet the requirements of Chrysler Material Standard MS-10725. The manufacturer	1 Quart - 05127394AB	7 Quarts	6.6 Liters

	recommends the use of a full synthetic engine oil, such as Pennzoil Platinum® European Formula SAE 5W-40 or equivalent.			
Engine Oil (3.0L Diesel Engine)	API Certified SAE 5W-30 Synthetic Engine Oil, meeting the requirements of Chrysler Material Standard MS-11106 or Mercedes Benz MB 229.51 and ACEA C3 qualified engine oils.	1 Liter - 68001334AA	10 Quarts	9.5 Liters
Engine Oil Filter (3.7L gasoline Engines)	MOPAR® Engine Oil Filter	05184231AA	N/A	N/A
Engine Oil Filter (4.7/5.7/6.1L gasoline Engines)	MOPAR® Engine Oil Filter	04884899AB	N/A	N/A
Engine Oil Filter (3.0L Diesel engine)	MOPAR® Engine Oil Filter	05175571AA	N/A	N/A
<b>Fuel (approximate)</b>				
Fuel Selection (3.7L and 4.7L Engines) Domestic	87 Octane, (R + M)/2 method	N/A	21 Gallons	79 Liters
Fuel Selection (3.7L and 4.7L Engines) Export	91 Octane	N/A	27 Gallons	102 Liters
Fuel Selection (5.7L Engine) Domestic	87 Octane Acceptable - 89 Octane Recommended	N/A	21 Gallons	79 Liters
Fuel Selection (5.7L Engine) Export	91 Octane Acceptable - 95 Octane Recommended	N/A	27 Gallons	102 Liters
Fuel Selection (6.1L Engine) Domestic Only	Premium Unleaded - 91 Octane or Higher Only	N/A	21 Gallons	79 Liters
Fuel Selection (3.0L Diesel Engine) Domestic	Use only the best quality fuel with a calculated Cetane Index of 42–46. In addition, the manufacturer recommends using diesel fuel with a sulfur content of <b>less than or equal to 15 ppm</b> .	N/A	22 Gallons	83 Liters
Fuel Selection (3.0L Diesel)	Use good quality diesel fuel from a reputable supplier in your vehicle. The manufacturer requires that you must fuel this vehicle with Ultra Low Sulfur Highway Diesel fuel (15 ppm Sulfur maximum) and prohibits the use of Low Sulfur Highway Diesel fuel (500 ppm Sulfur maximum) to avoid damage to the emissions control system. For most year-round service, No. 2 diesel fuel meeting ASTM specification D-975 Grade S15 will provide good performance. If the vehicle is	N/A	22	83 Liters

Engines)	exposed to extreme cold (below 20F or -7C), or is required to operate at colder-than-normal conditions for prolonged periods, use climatized No. 2 diesel fuel or dilute the No. 2 diesel fuel with 50% No. 1 diesel fuel. This will provide better protection from fuel gelling or wax-plugging of the fuel filters. This vehicle is fully compatible with biodiesel blends up to 5% biodiesel meeting ASTM specification D-975.		Gallons	
<b>A/C Refrigerant System</b>				
A/C Refrigerant	R-134a	82300101AB	1.5 Pounds	0.68 Kilograms
◆ System fill capacity includes heater and coolant recovery bottle filled to MAX level.				
◆◆ SAE 5W-30 engine oil approved to MB 229.31 or MB 229.51 may be used when SAE 5W-20 engine oil is not available.				
◆◆◆ For countries that use the ACEA European Oil Categories for Service Fill Oils, use the recommended engine oil that meets the requirements of ACEA C3, and approved to MB 229.31 or MB 229.51 only. Refer to your engine oil filler cap for correct SAE grade.				
<b>CAUTION:</b> Nominal refill capacities are shown. A variation may be observed from vehicle to vehicle due to manufacturing tolerance and refill procedure.				

## SPARK PLUGS

Description	Type	Part Number	Gap	
			U.S.	Metric
Spark Plugs (3.7L Engine)	NGK® Nickel	56028356AA (ZFR6F-11G)	0.044 in	1.10 mm
Spark Plugs (4.7L Engine)	BOSCH® Nickel Yttrium (intake side)	05149050AB (FR9 TE2)	0.039 in	1.00 mm
	BOSCH® Iridium / Platinum (exhaust side)	05149888AA (FR8 T1332)	0.050 in	1.27 mm
Spark Plugs (5.7L Engine)	Champion® Spark Plug	REC14MCC4 (SPREC14MCC4)	0.043 in	01.10 mm
Spark Plugs (6.1L Engine)	NGK® Double Platinum	05037404AA (PLZTR5A-13)	0.051 in	01.30 mm

## TRANSMISSION

			<b>Capacities</b>
--	--	--	-------------------

Description	Type	Part Number	U.S.	Metric
<b>Automatic</b>				
545RFE - Service Fill	MOPAR® ATF+4 Automatic Transmission Fluid	1 Quart - 05013457AA	4X2 - 5.5 Quarts	4X2 - 5.2 Liters
		1 Gallon - 05013458AA		
		1 Quart - 05013457AA	4X4 - 6.5 Quarts	4X4 - 6.2 Liters
		1 Gallon - 05013458AA		
◆ 545RFE - Overhaul Fill	MOPAR® ATF+4 Automatic Transmission Fluid	1 Quart - 05013457AA	4X2 - 14.8 Quarts	4X2 - 14 Liters
		1 Gallon - 05013458AA		
		1 Quart - 05013457AA	4X4 - 16.9 Quarts	4X4 - 16 Liters
		1 Gallon - 05013458AA		
NAG 1 - Service Fill	MOPAR® ATF+4 Automatic Transmission Fluid	1 Quart - 05013457AA	5.3 Quarts	5.0 Liters
		1 Gallon - 05013458AA		
◆ NAG 1 - Overhaul Fill	MOPAR® ATF+4 Automatic Transmission Fluid	1 Quart - 05013457AA	8.1 Quarts	7.7 Liters
		1 Gallon - 05013458AA		
◆ Dry fill capacity. Depending on type and size of internal cooler, length and inside diameter of cooler lines, or use of an auxiliary cooler, these figures may vary. Refer to the appropriate service information for the correct procedures.				
<b>CAUTION:</b> Nominal refill capacities are shown. A variation may be observed from vehicle to vehicle due to manufacturing tolerance and refill procedure.				

### TRANSFER CASE

Description	Type	Part Number	Capacities	
			U.S.	Metric

NV140	MOPAR® ATF+4 Automatic Transmission Fluid	1 Quart - 05013457AA	1.4 Pints	0.65 Liters
		1 Gallon - 05013458AA		
◆ NV146 (6.1L engine Only)	MOPAR® Transfer Case Fluid NV146	1 Quart - 68001758AA	1.4 Pints	0.65 Liters
NV245	MOPAR® Transfer case Lubricant NV24Z / NV247 / NV249	1 Quart - 05016796AB	3.8 Pints	1.8 Liters
◆ Mopar ® NV146 Transfer Case Fluid. Usage of other fluid/lubricants is <b>NOT</b> recommended.				
<b>CAUTION:</b> Nominal refill capacities are shown. A variation may be observed from vehicle to vehicle due to manufacturing tolerance and refill procedure.				

## CHASSIS

Description	Type	Part Number	Capacities	
			U.S.	Metric
<b>Axles (Front)</b>				
◆ C200F and C200FE - Front Axle	MOPAR® Synthetic Gear Lubricant SAE 75W-140	1 Quart - 04874469AA	3.6 Pints	1.7 Liters
<b>Axles (Rear)</b>				
C213R -Rear Axle	MOPAR® Synthetic Gear Lubricant SAE 75W-140	1 Quart - 04874469AA	4.4 Pints	2.07 Liters
◆ C213R RE - Rear Axle	MOPAR® Synthetic Gear Lubricant SAE 75W-140	1 Quart - 04874469AA	4.4 Pints	2.07 Liters
<b>Chassis Systems</b>				
◆◆ Brake Master Cylinder	MOPAR® Brake Fluid DOT 3, SAE J1703.	12 oz. Bottle - 04318080AB	N/A	N/A
		32 oz. Bottle - 04318081AB		
Power Steering Reservoir	MOPAR® HYDRAULIC System Power Steering Fluid	1 Quart - 05142893AA	N/A	N/A
◆ Limited-Slip Rear Axles require the addition of 118 ml (4 oz.) MOPAR® Limited Slip Additive.				
◆◆ If MOPAR® Brake Fluid DOT 3 is not available, then MOPAR® Brake and Clutch Fluid DOT 4 (04549625AC), is acceptable.				

**CAUTION:** Nominal refill capacities are shown. A variation may be observed from vehicle to vehicle due to manufacturing tolerance and refill procedure.



## 07 - Cooling/Standard Procedure

# STANDARD PROCEDURE - FILLING

**WARNING:** ANTIFREEZE COOLANT IS HARMFUL IF SWALLOWED OR INHALED. IF SWALLOWED, DRINK TWO GLASSES OF WATER AND INDUCE VOMITING. IF INHALED, MOVE TO FRESH AIR AREA. SEEK MEDICAL ATTENTION IMMEDIATELY. DO NOT STORE IN OPEN OR UNMARKED CONTAINERS. WASH SKIN AND CLOTHING THOROUGHLY AFTER COMING IN CONTACT WITH ETHYLENE GLYCOL. KEEP OUT OF REACH OF CHILDREN. DISPOSE OF GLYCOL BASED COOLANT PROPERLY. CONTACT YOUR DEALER OR GOVERNMENT AGENCY FOR LOCATION OF COLLECTION CENTER IN YOUR AREA. DO NOT OPEN A COOLING SYSTEM WHEN THE ENGINE IS AT OPERATING TEMPERATURE OR HOT UNDER PRESSURE; PERSONAL INJURY CAN RESULT. AVOID RADIATOR COOLING FAN AND OTHER MOVING COMPONENTS WHEN ENGINE COMPARTMENT RELATED SERVICE IS PERFORMED; PERSONAL INJURY CAN RESULT.

**WARNING:** WEAR APPROPRIATE EYE AND HAND PROTECTION WHEN PERFORMING THIS PROCEDURE.

**CAUTION:** Do not use well water or suspect water supply in cooling system. A 50/50 mixture of the recommended antifreeze coolant and distilled water is recommended.

**NOTE:** Cooling system fill procedure is critical to overall cooling system performance.

**NOTE:** Make sure all hoses are connected and radiator draincock is closed. Draincock should be hand tightened only.

**WARNING:** When installing drain hose to air bleed valve, route hose away from accessory drive belts, accessory drive pulleys, and electric cooling fan motors.

**NOTE:** It is imperative that the cooling system air bleed valve be opened before any coolant is added to the cooling system. Failure to open the bleed valve first will result in an incomplete fill of the system.

1. Open cooling system bleed valve.
2. Attach a 1.5 - 2 m (4 - 6 ft.) long 6.35 mm (1/4 inch) ID clear hose to bleeder fitting
3. Route hose (2) away from the accessory drive belt, drive pulleys and electric cooling fan. Place the other end of hose (2) into a clean container. The hose will prevent coolant from contacting the accessory drive belt when bleeding the system during the refilling operation.
4. 5.7L/6.1L ENGINE - Install a threaded and barbed fitting (1/4 - 18 npt) into water pump housing.
5. If using funnel 8195:
  - a. Remove cooling system pressure cap. Attach Filling Aid Funnel [Funnel 8195](#) , to coolant pressure container filler neck.
  - b. Use the supplied clip to pinch overflow hose that connects between the two chambers of the pressure

container.

- c. Pour coolant into the larger section of Filling Aid Funnel (the smaller section of funnel is to allow air to escape).
- d. Continue filling until a steady stream of coolant flows from attached hose on bleed valve.
- e. Close bleed valve and continue filling system to top of Filling Aid Funnel. DO NOT overtighten. Tighten to 12.4 N·m (110 lbs. in.).
- f. Remove clip from overflow hose.
- g. Allow coolant in Filling Aid Funnel to drain into overflow chamber of pressure container.
- h. Remove Filling Aid Funnel [Funnel 8195](#)
- i. Install the pressure cap.

**NOTE:** The 8195A does not require pinching off the overflow hose. The adapter seal prevents liquid from entering the overflow during coolant fill.

6. If using Special Tool 8195A:
  - a. Select the appropriate fitting extension (3), locking ring (2) and attach to the fill neck of the cooling system.
  - b. Make sure the adapter seal fits firmly against the inside of the fill neck base to ensure a good seal. After the extension and locking ring are installed, make sure the extension can not be moved. This will confirm a good seal.
  - c. Attach the funnel (1) to the extension (3) and fill with coolant.
  - d. Once the coolant no longer drains into the system and remains in the funnel, start the engine and run to operating temperature.
  - e. Once the thermostat has opened and the air has exited the system into the funnel, squeeze the upper radiator hose to further assist in air removal.
  - f. Install the stopper (4) into the funnel base. The stopper will prevent the fluid that is left in the funnel from spilling out when separated from the extension.
  - g. Remove the funnel, extension and locking ring and install the cap.
7. Remove the hose from the bleed valve.
8. Start the engine and allow to run until the thermostat opens and the radiator fan cycles on.
9. Shut off engine and allow it to cool down. This permits coolant to be drawn into the pressure chamber.
10. With engine COLD, observe coolant level in pressure chamber. Coolant level should be within MIN and MAX marks. Adjust coolant level as necessary.

