

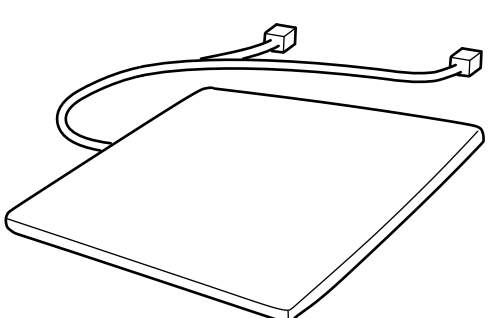

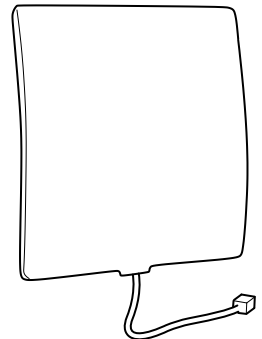

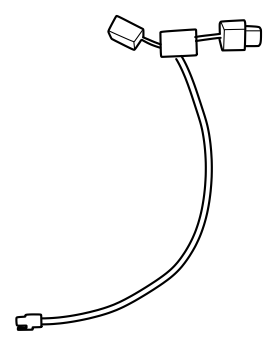

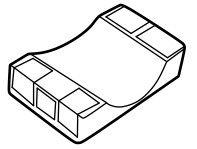

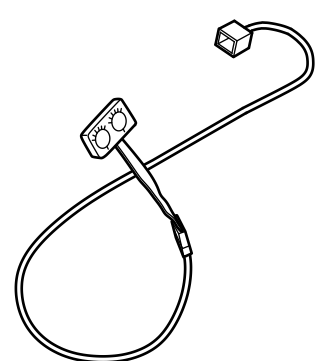
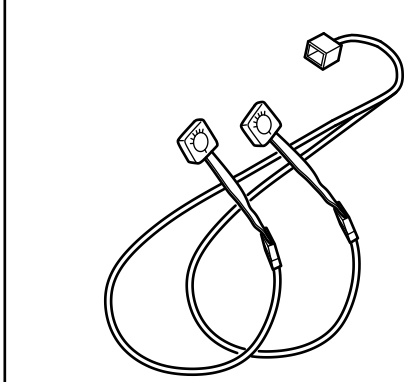

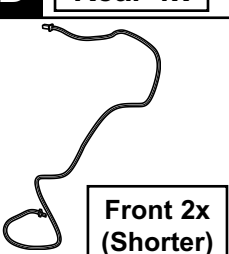

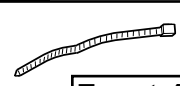

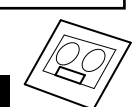



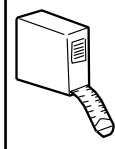
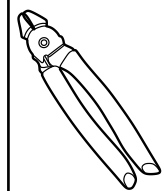
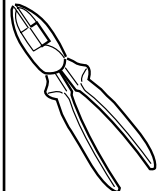

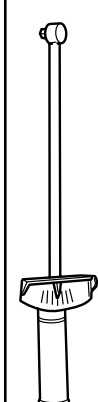
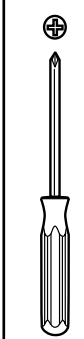
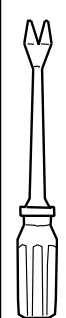
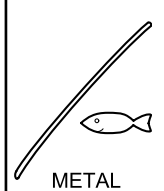
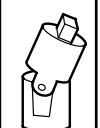
MOPAR®

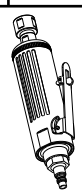
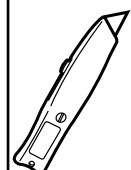
# JEEP GRAND CHEROKEE

## Front and / or Rear Heated Seat

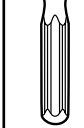
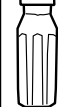
 <b>A</b> Front 2x Rear 2x	 <b>B</b> Front 2x Rear 2x	 <b>C</b> Front 1x Rear 1x								
 <b>D</b> Front 1x Rear 1x	 <b>F</b> Rear 1x	 <b>G</b> Front 1x	 <b>L</b> Front 1x							
 <b>E</b> Front 2x (Shorter) Rear 2x (Longer)	 <b>H</b> Rear 1x	 <b>I</b> Front 2x	 <b>J</b> Front 10x Rear 10x							
 <b>M</b> Front 2x Rear 2x	 <b>N</b> Front 1x Rear 1x	 <b>K</b> Rear 1x	 <b>O</b> Front 18x Rear 18x							
										 METAL
		 1/8"			 15mm					

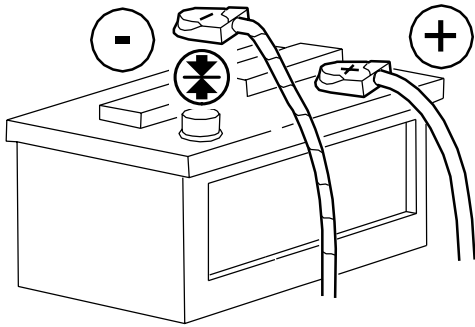

**1**

NOTE: REPEAT FOR OPPOSITE SIDE

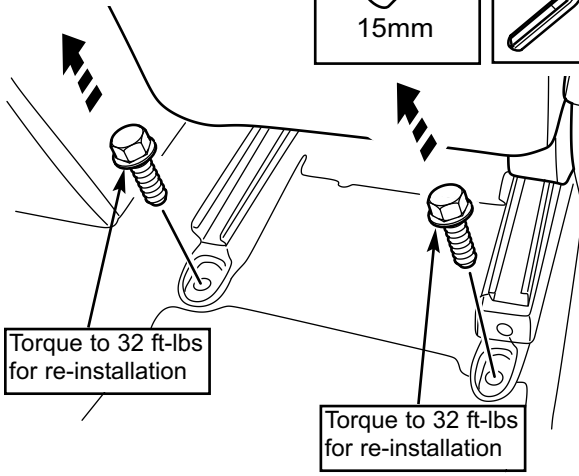
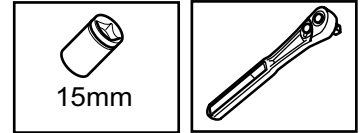

**2**

**FRONT & REAR SEAT KITS**

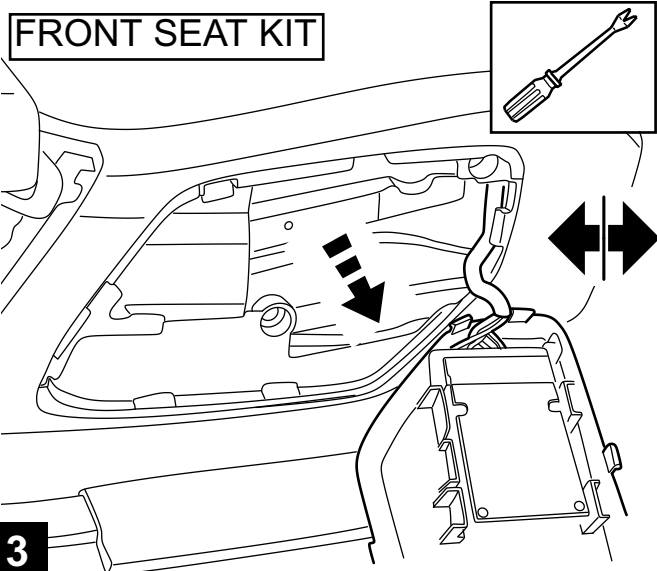

**3**

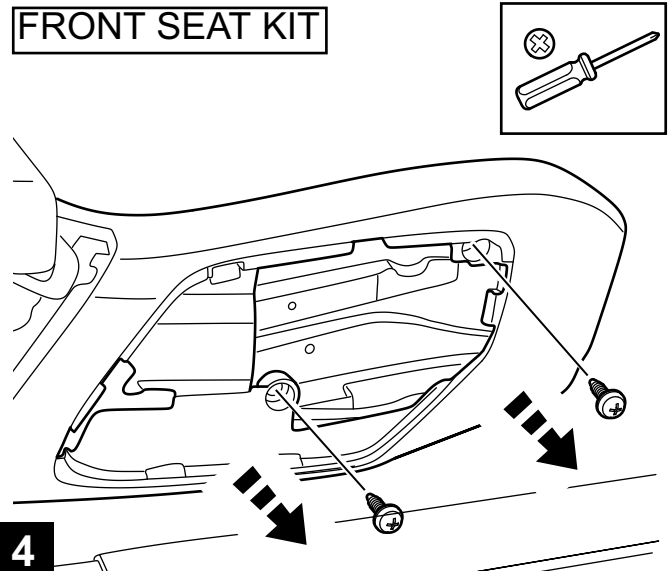

**4**

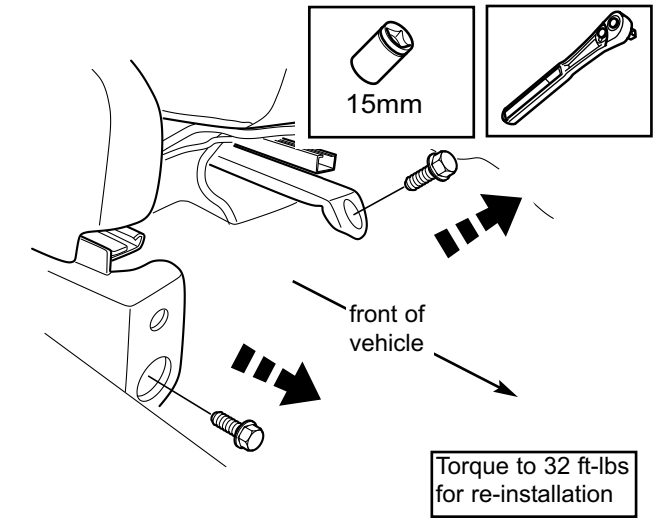

**5**

**FRONT & REAR SEAT KITS**

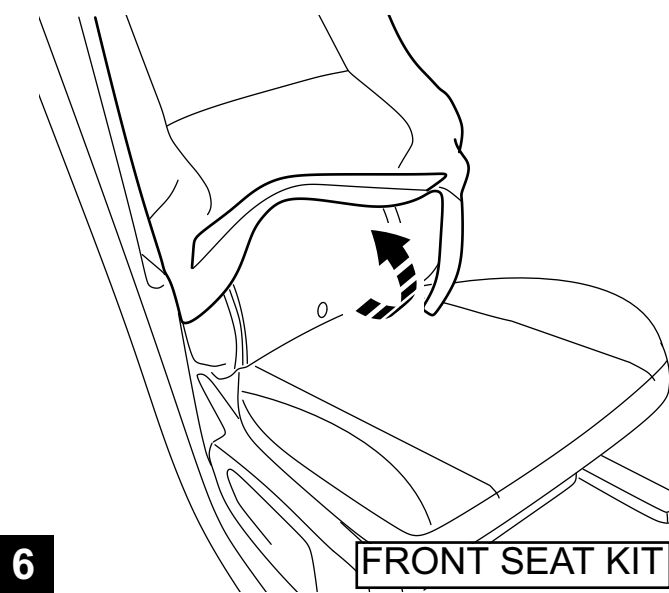

**6**

**FRONT SEAT KIT**

NOTE: USE ITEM O TO REINSTALL

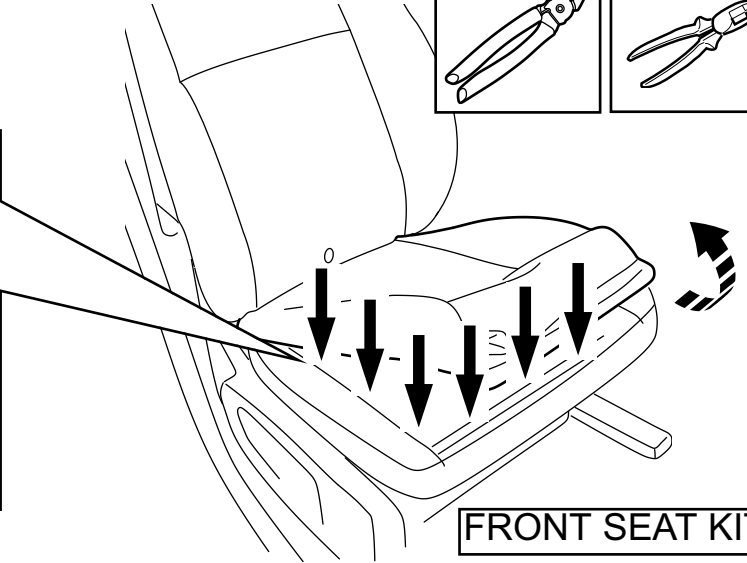
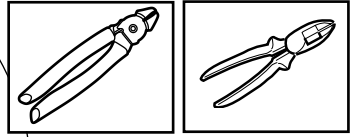
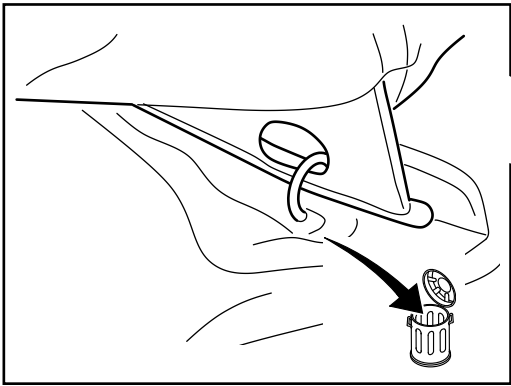

FRONT SEAT KIT

7

Note: Element must be centered on seat. Spacing between edge of element and inner ridge of cushion/pad must be equal to opposite side.

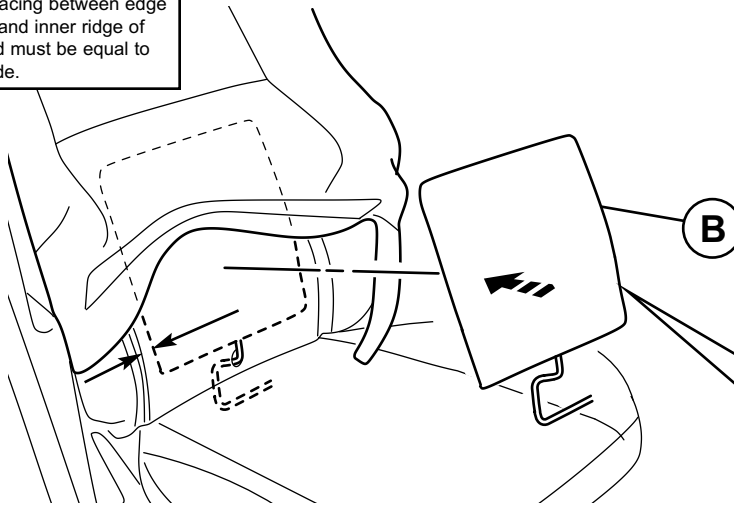

FRONT SEAT KIT

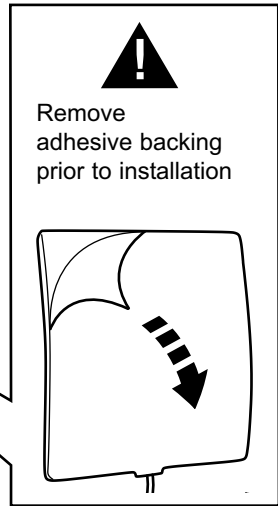

8

Note: Element must be centered on seat. Spacing between edge of element and inner ridge of cushion/pad must be equal to opposite side.

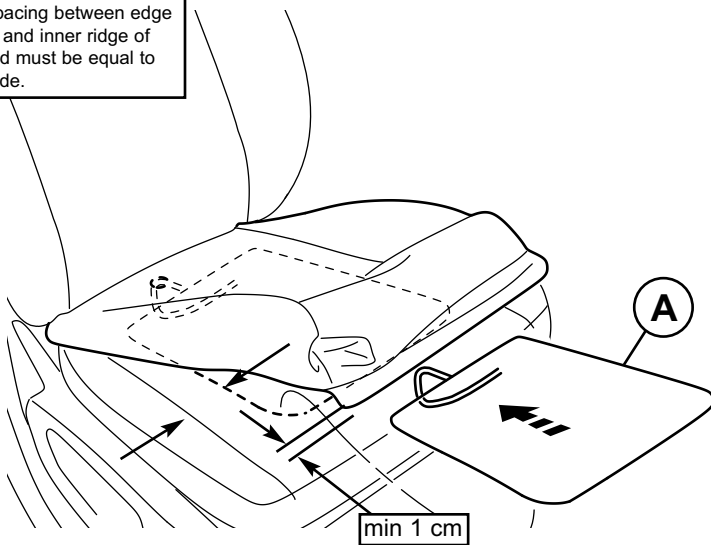

FRONT SEAT KIT

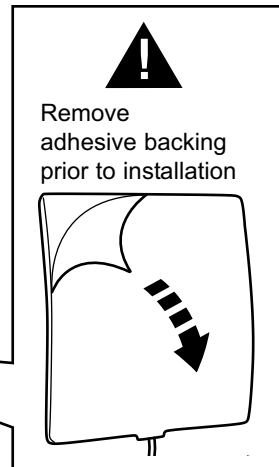

9

NOTE: USE ITEM J TO TIE STRAP AS NEEDED

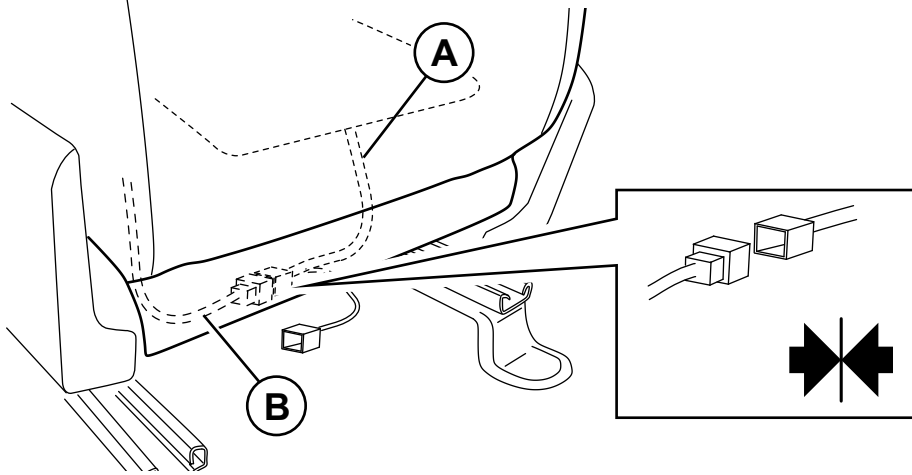

10

FRONT SEAT KIT

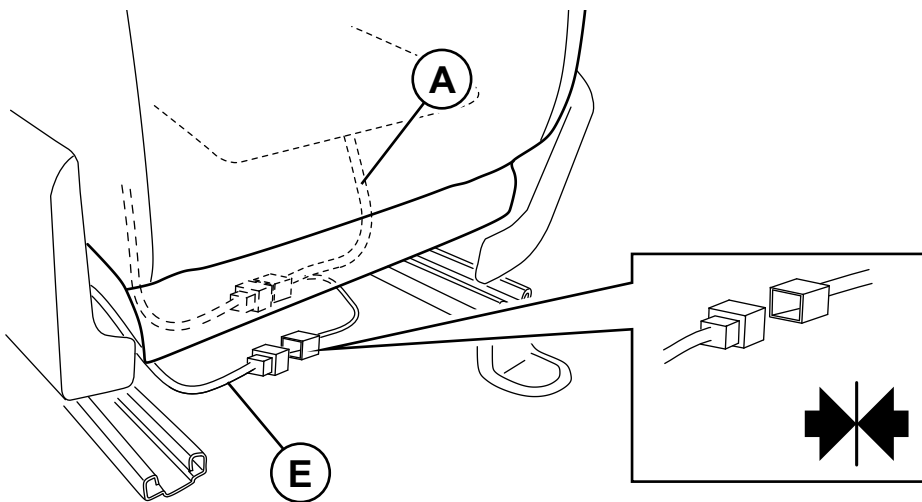

11

FRONT SEAT KIT

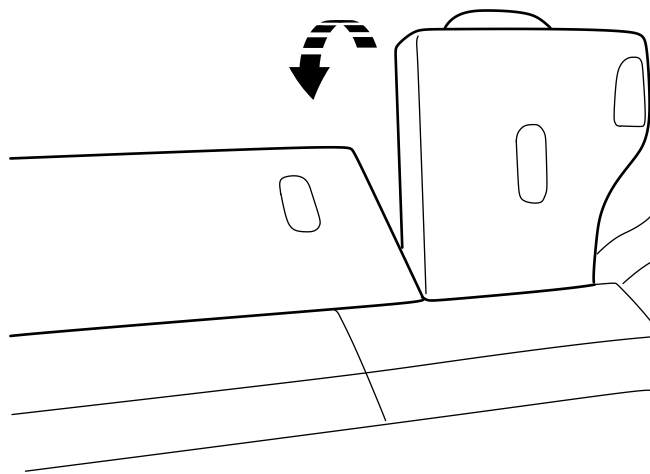

12

REAR SEAT KIT

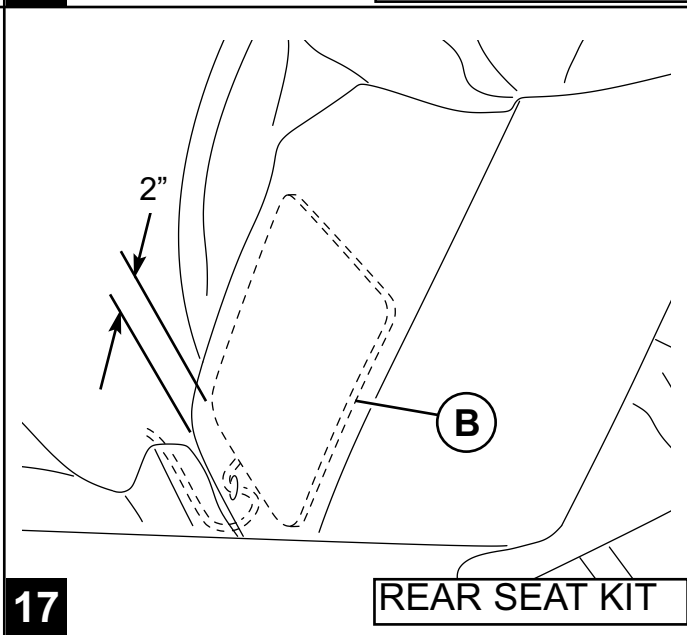
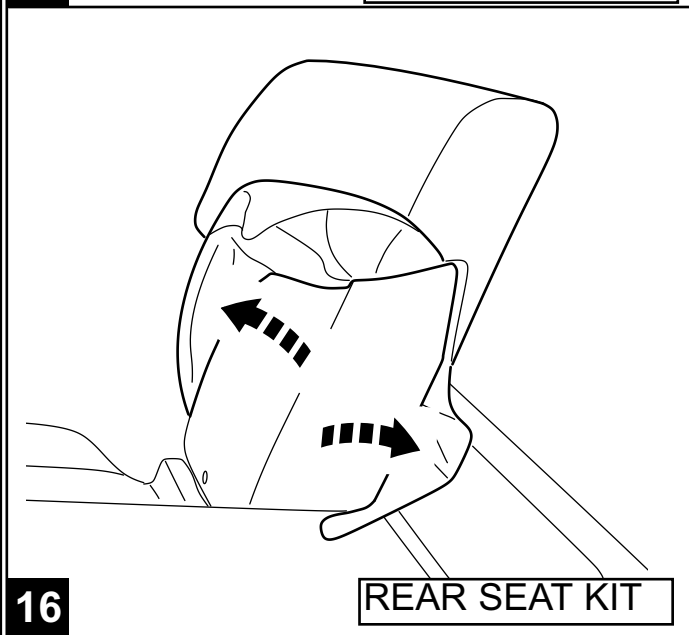
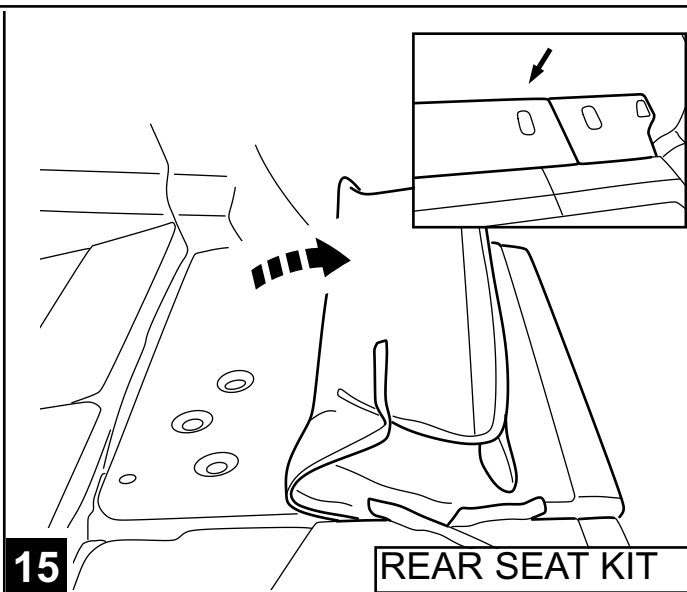
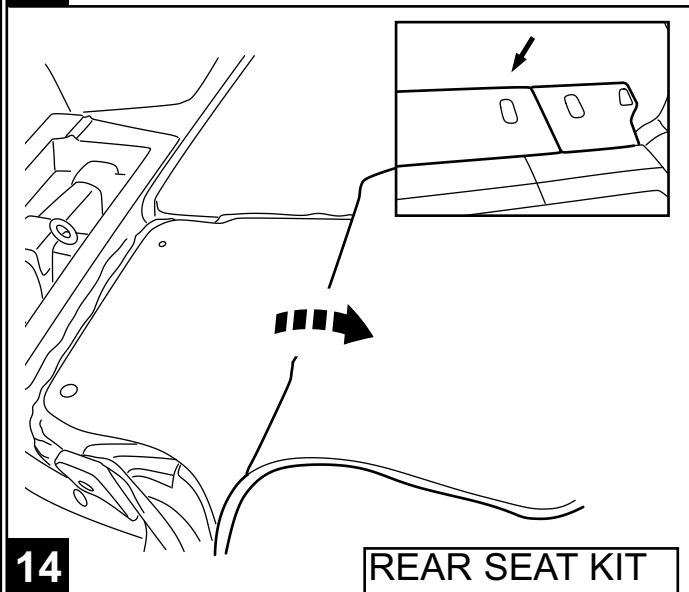
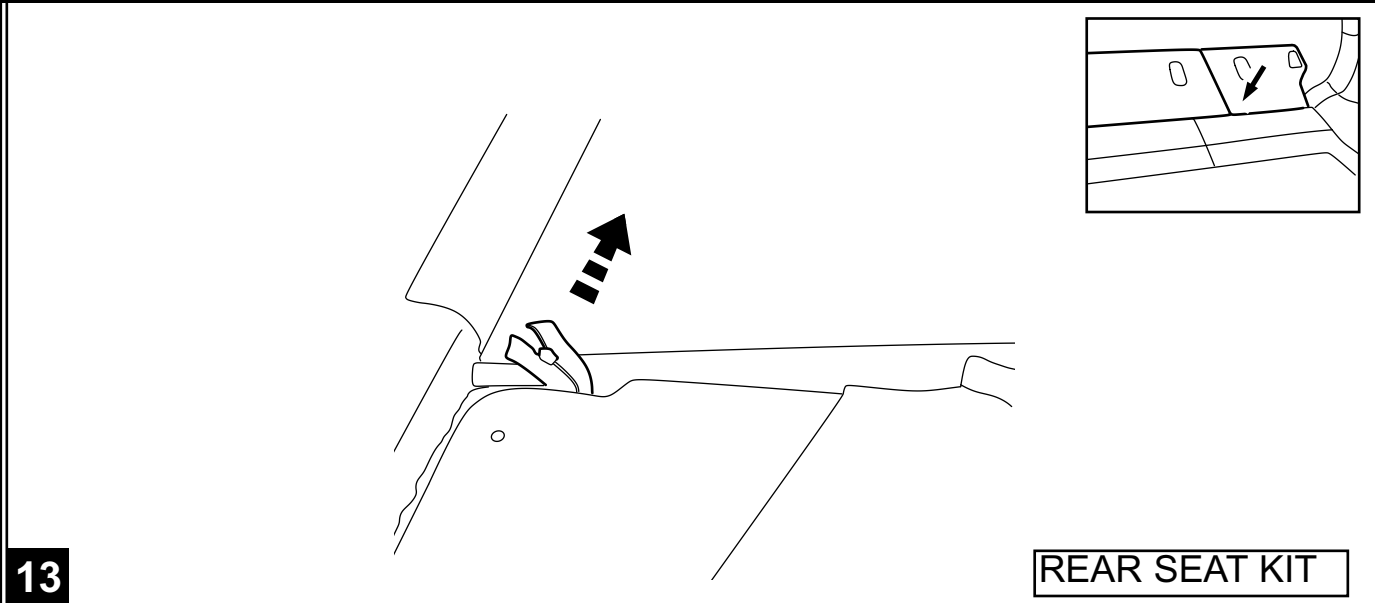

REAR SEAT KIT

REAR SEAT KIT

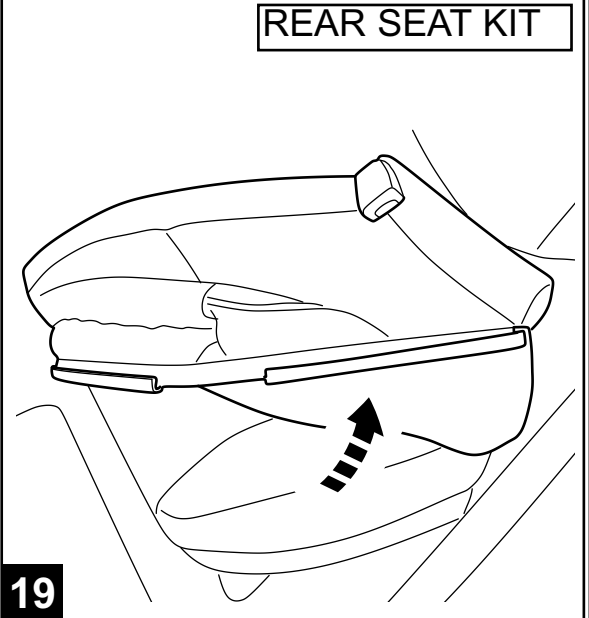
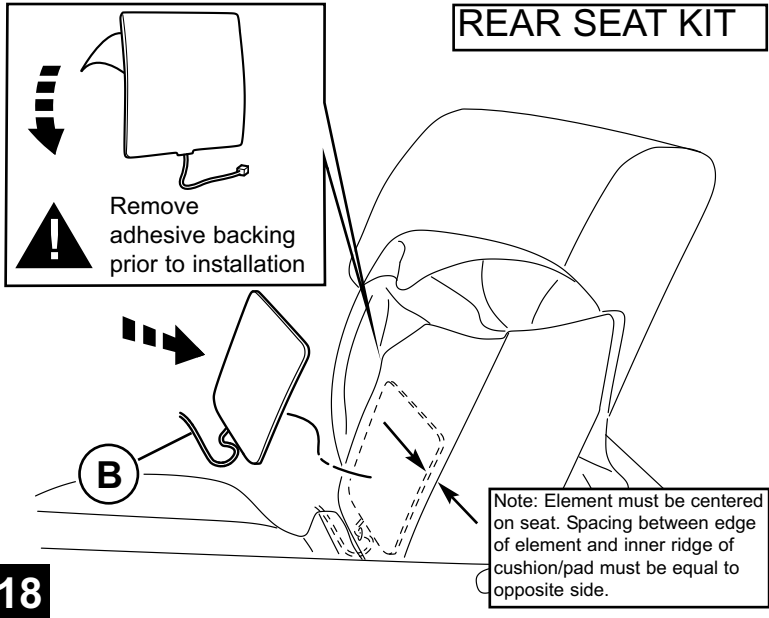

18

19

Note: Element must be centered on seat. Spacing between edge of element and inner ridge of cushion/pad must be equal to opposite side.

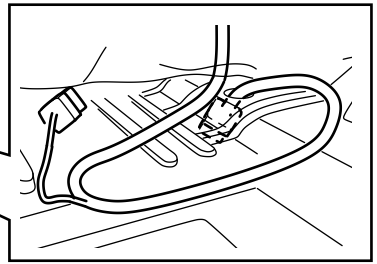
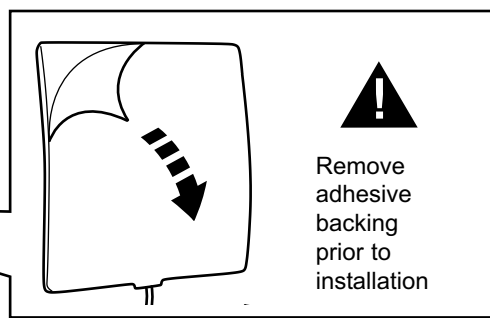
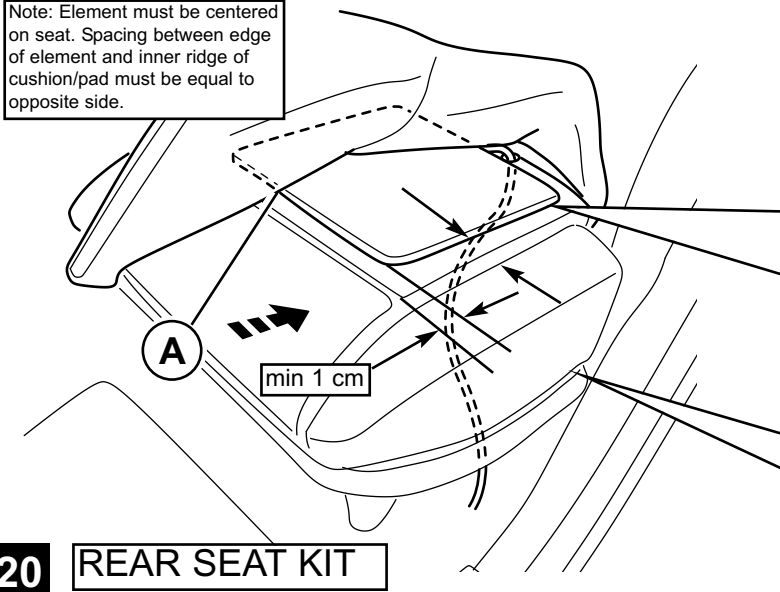

20

REAR SEAT KIT

NOTE: USE ITEM J TO TIE STRAP AS NEEDED

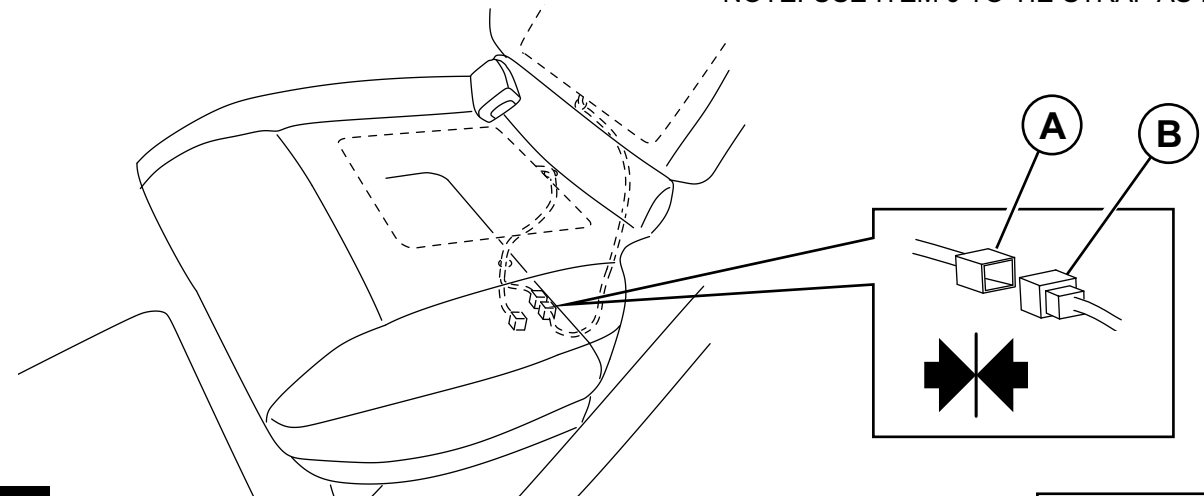

21

REAR SEAT KIT

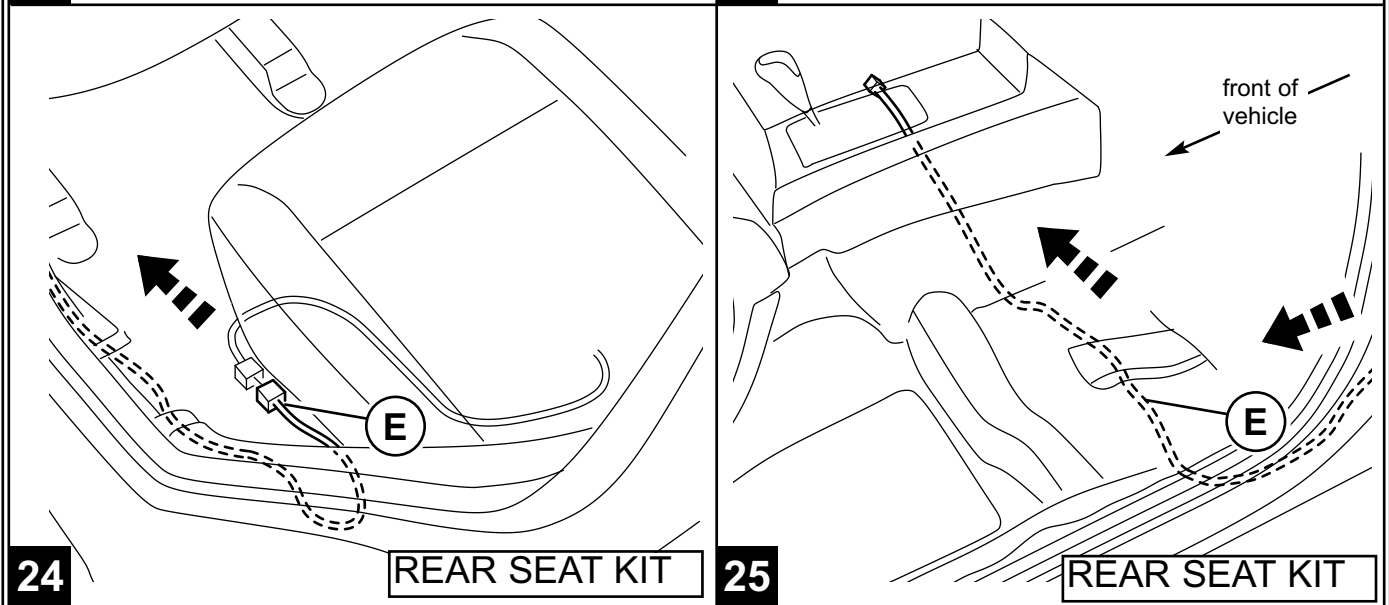
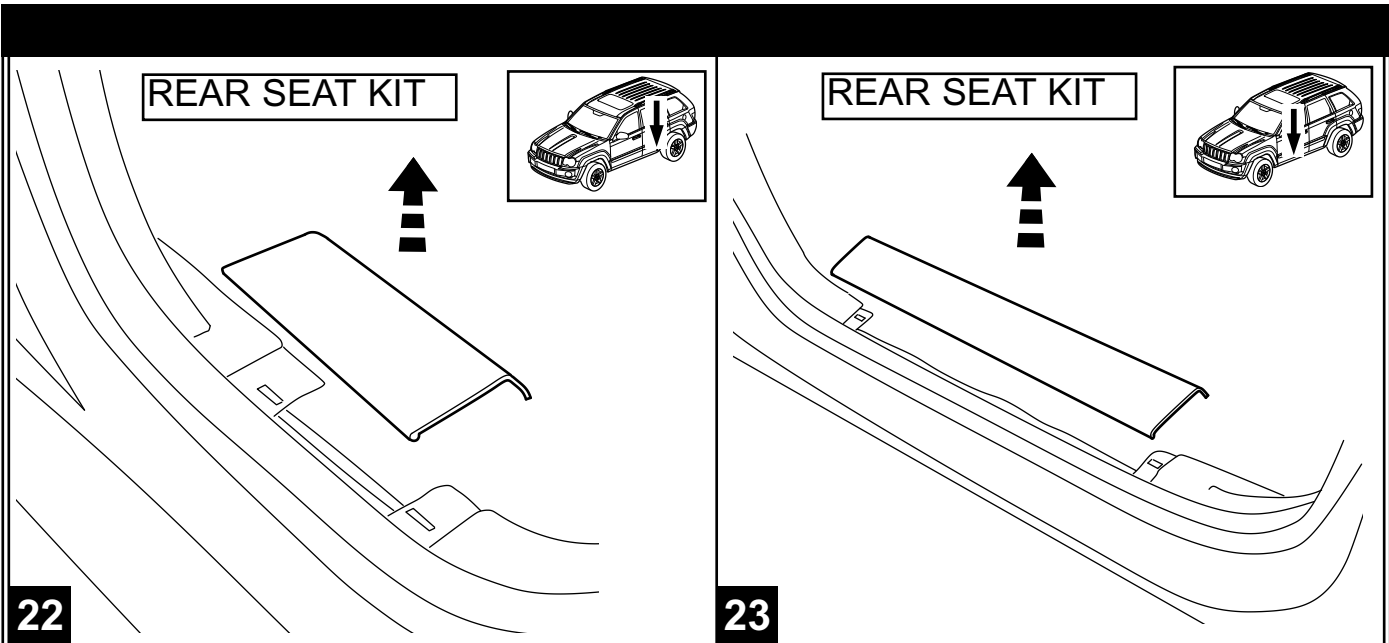

Repeat steps 2 - 25 for opposite side

**26**

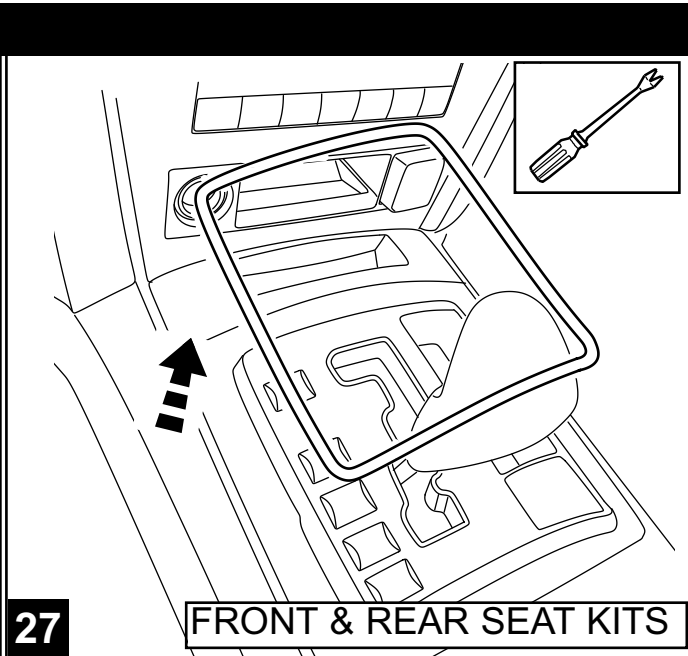

27

FRONT & REAR SEAT KITS

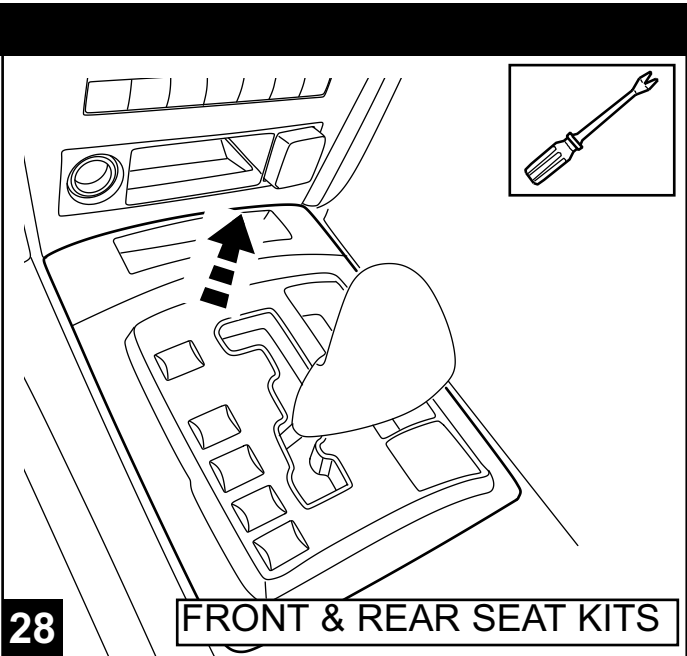

28

FRONT & REAR SEAT KITS

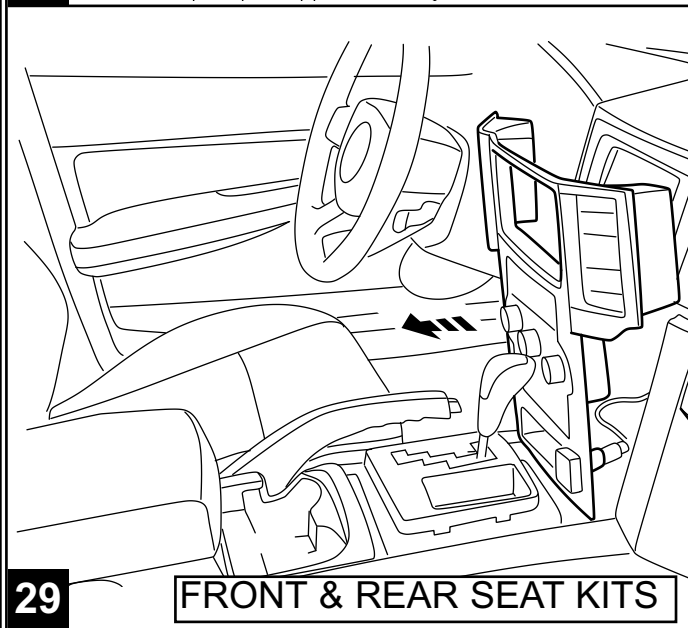

29

FRONT & REAR SEAT KITS

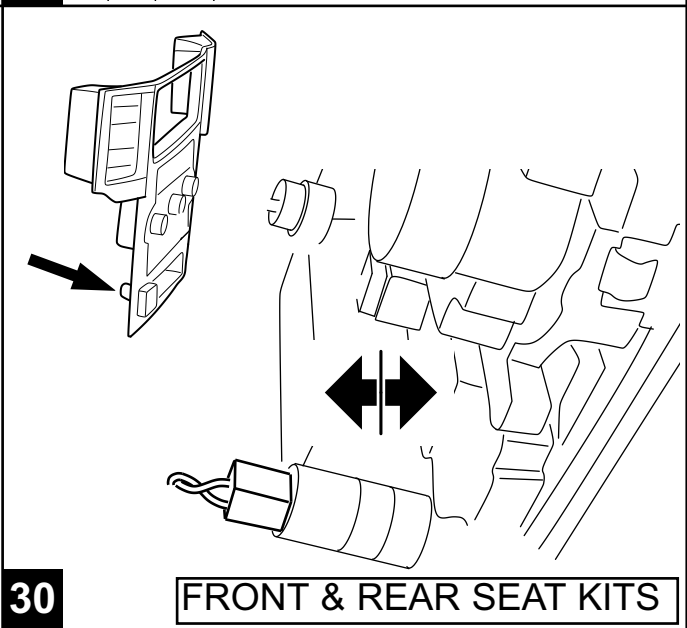

30

FRONT & REAR SEAT KITS

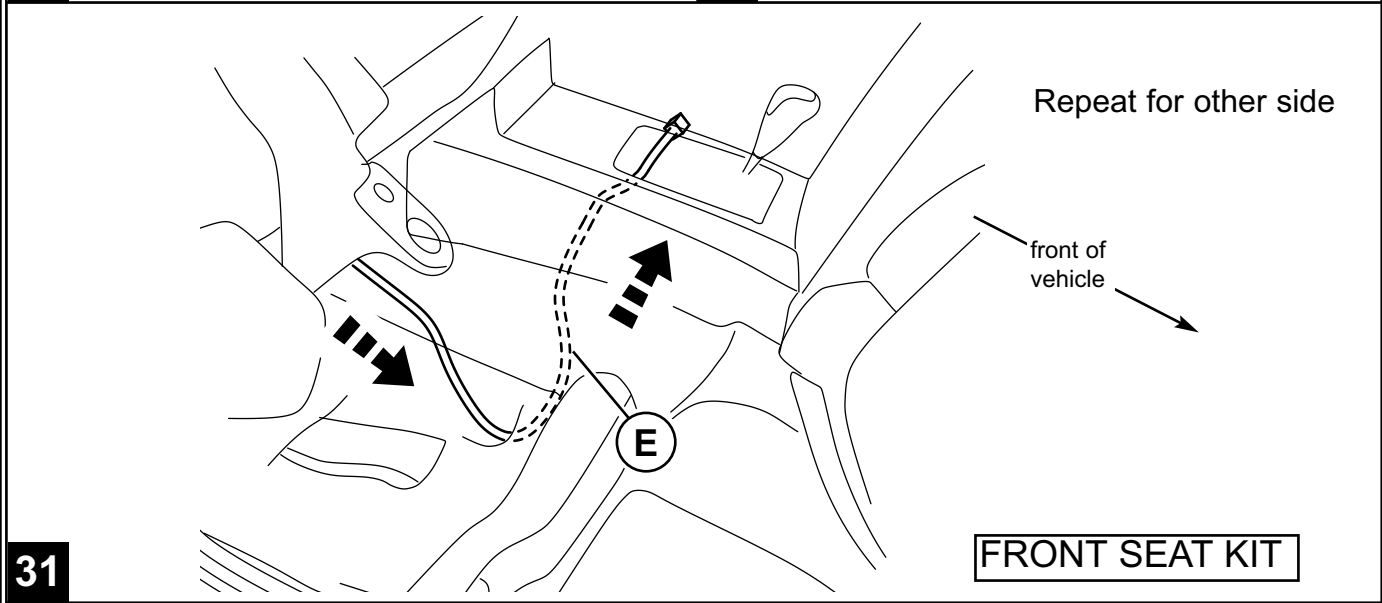

31

FRONT SEAT KIT



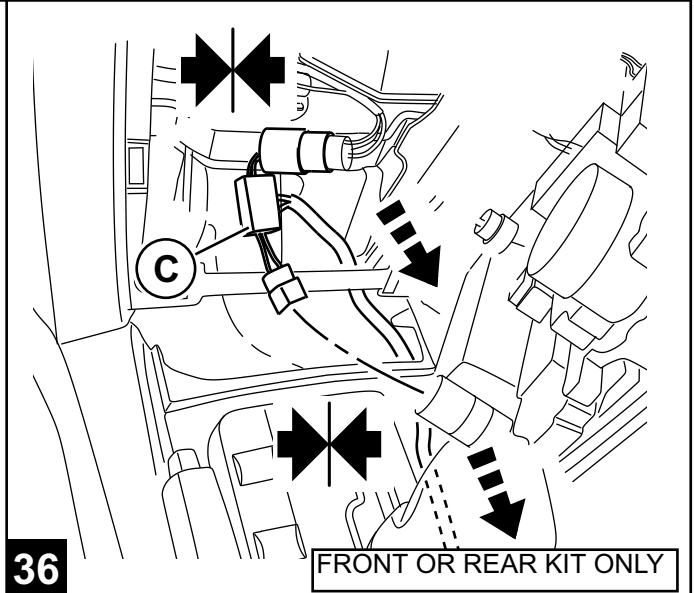
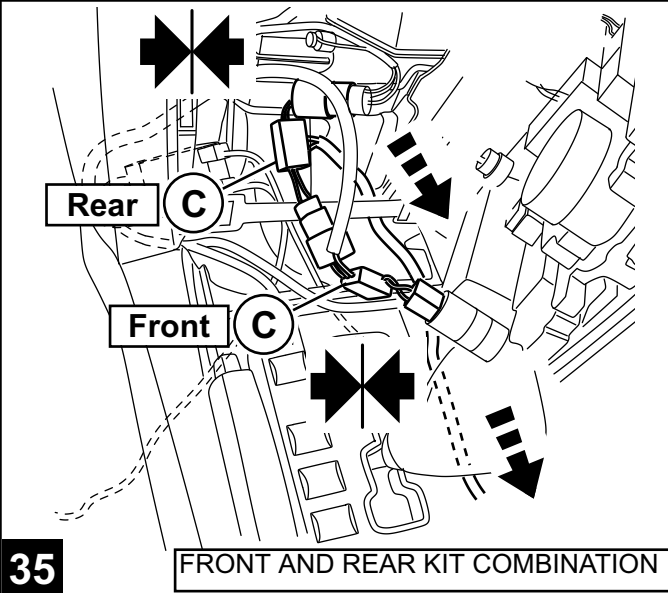
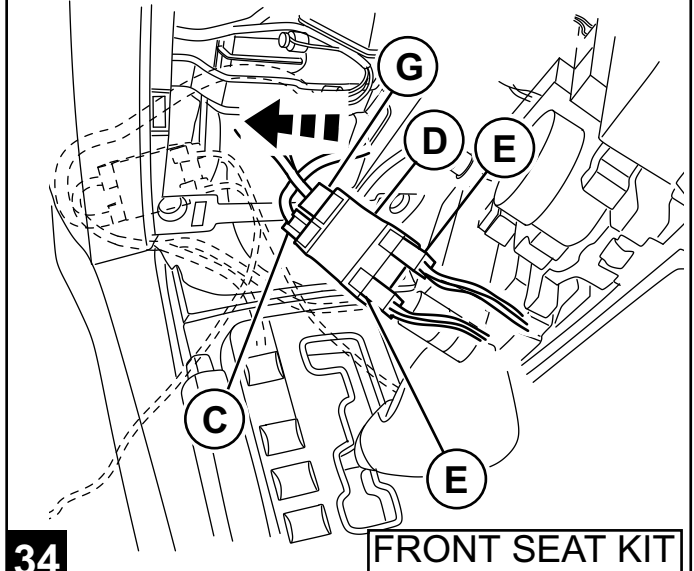
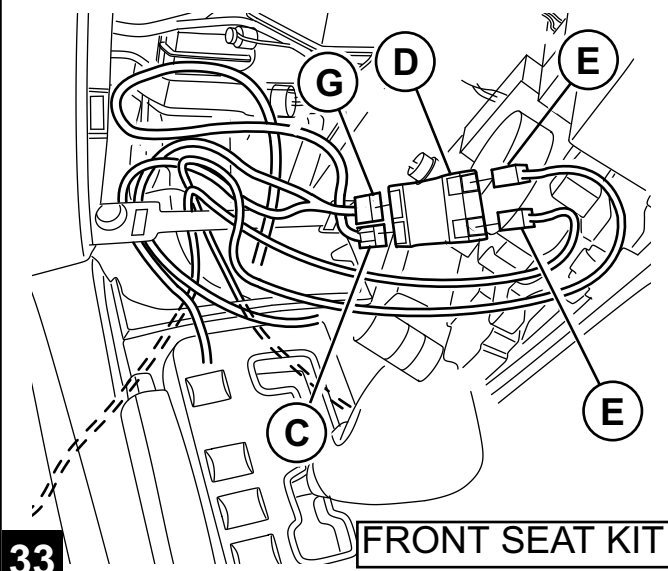
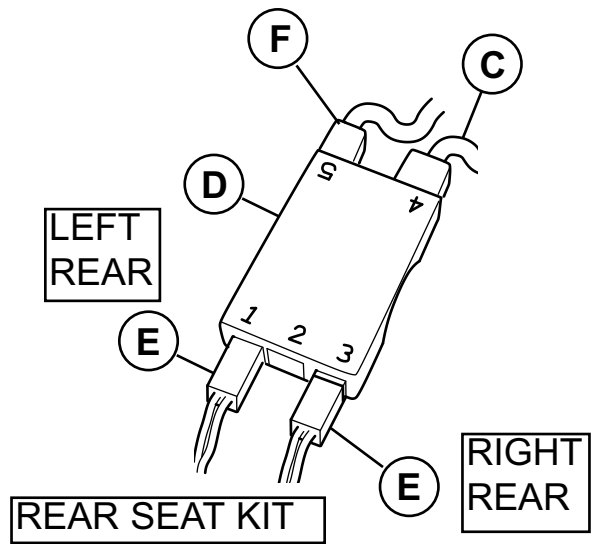
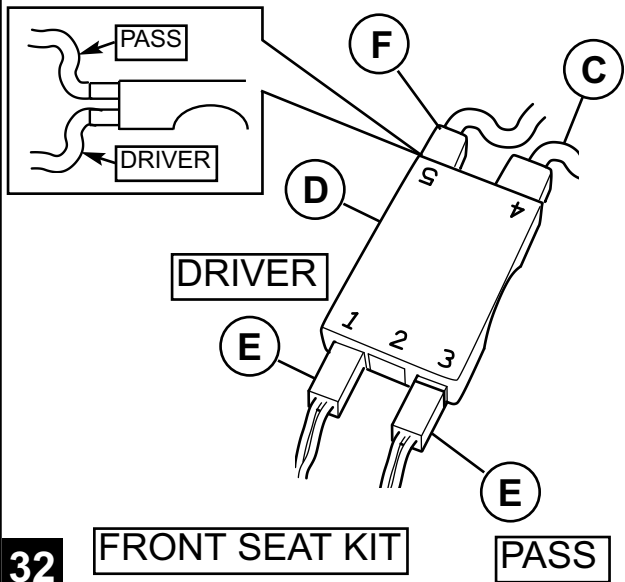

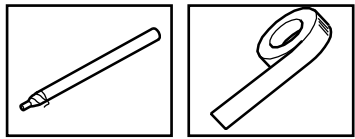

FRONT SEAT KIT

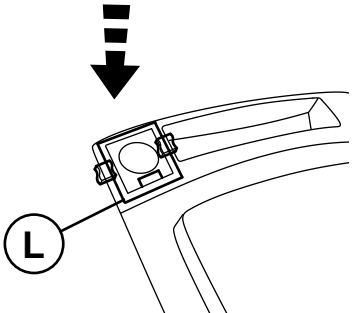

37 Repeat for other side

Repeat for other side

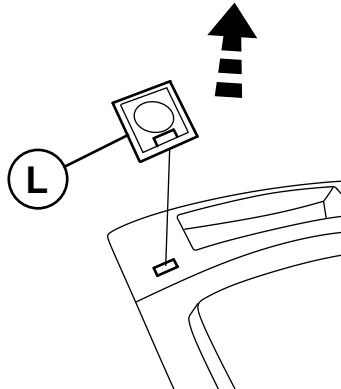

38 FRONT SEAT KIT

Repeat for other side

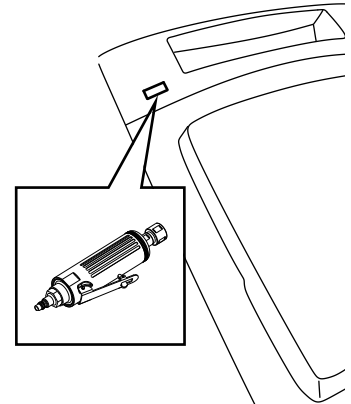

39 FRONT SEAT KIT

Repeat for other side

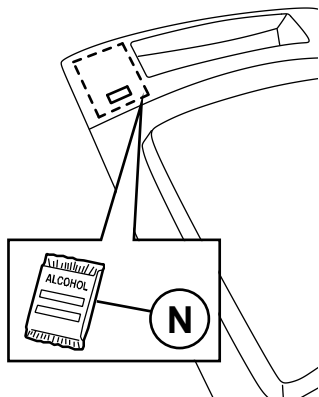

40 FRONT SEAT KIT

Repeat for other side

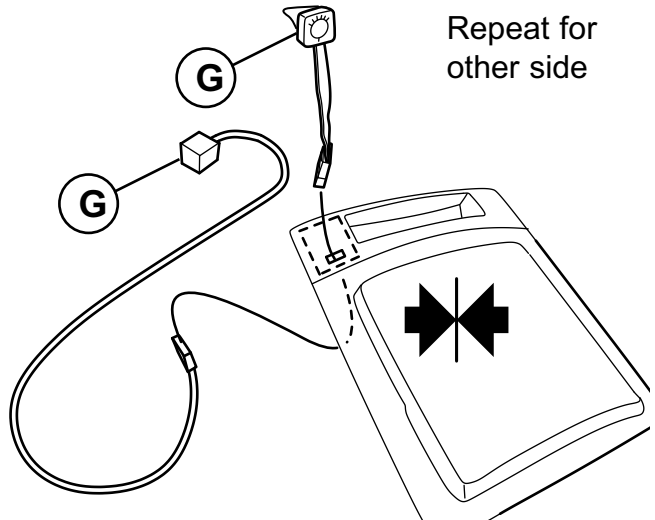

41 FRONT SEAT KIT

Repeat for other side

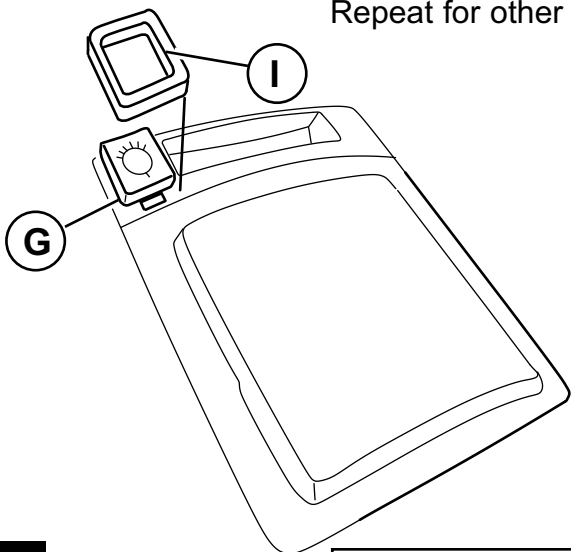

42 FRONT SEAT KIT

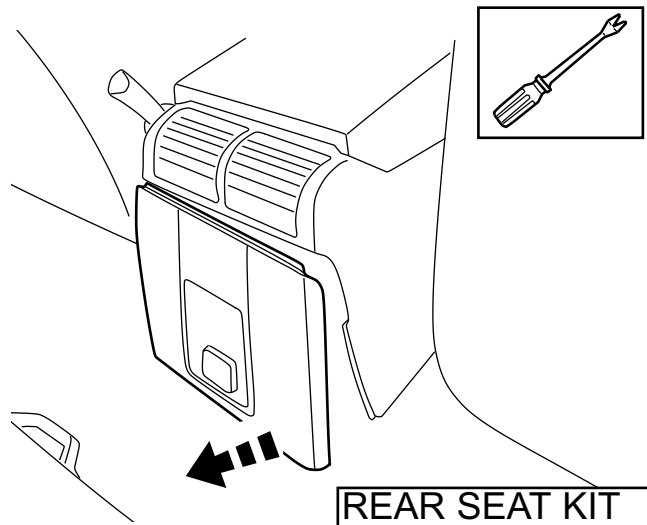

43 REAR SEAT KIT

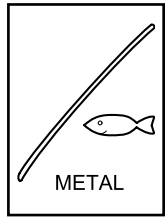
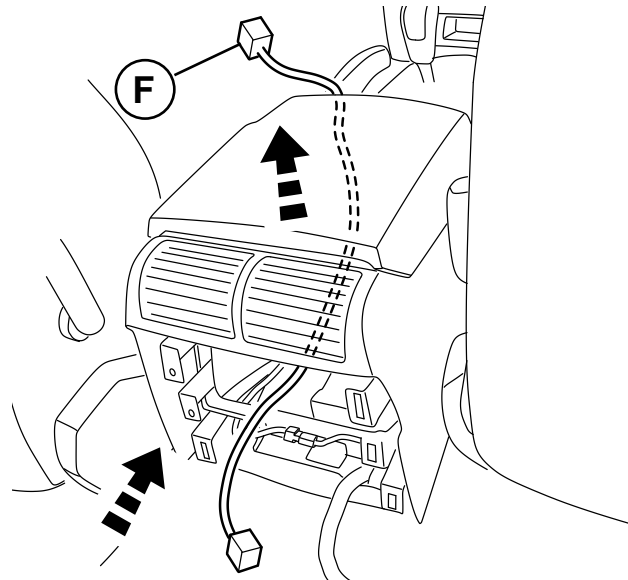

44

REAR SEAT KIT

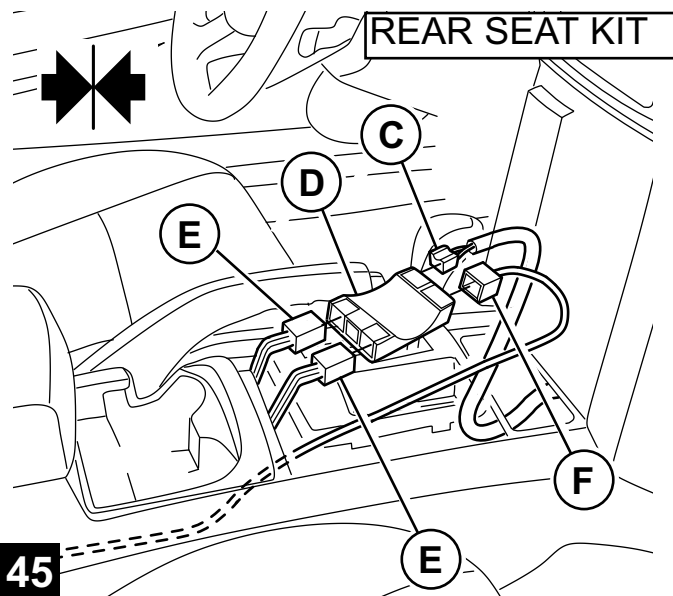

REAR SEAT KIT

45

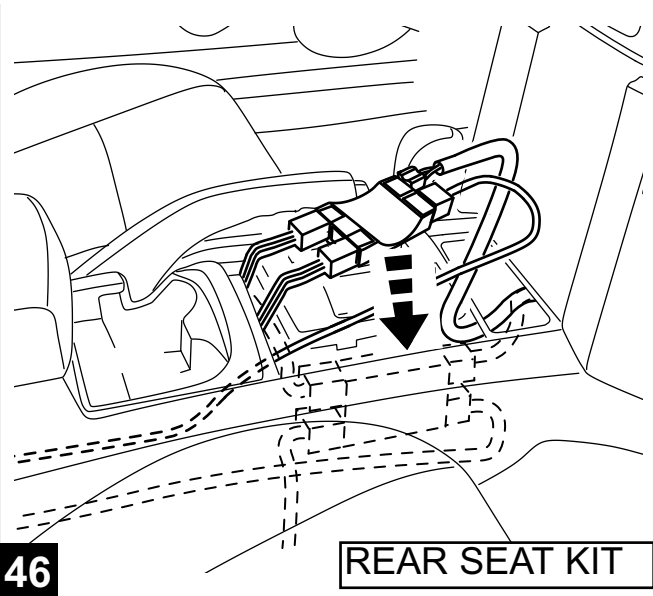

REAR SEAT KIT

46

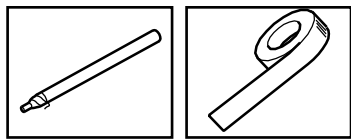

REAR SEAT KIT

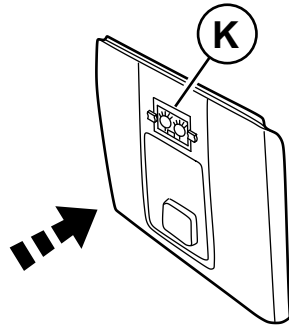

Center template onto bezel.

47

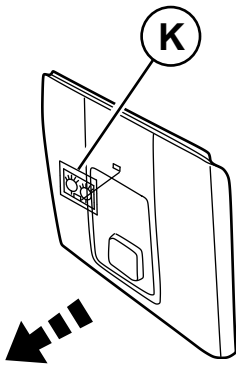

REAR SEAT KIT

48

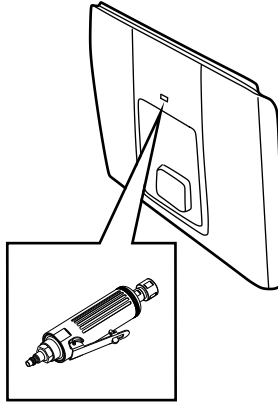

REAR SEAT KIT

49

REAR SEAT KIT

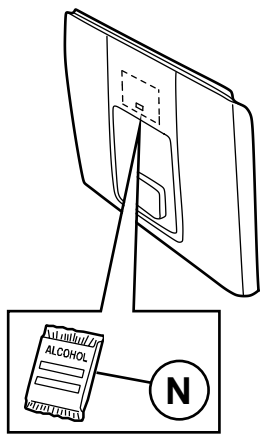

50

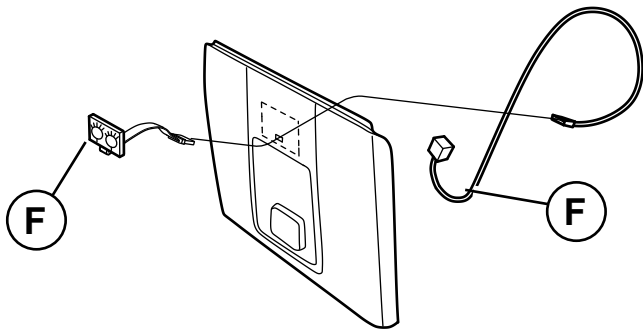

**51**

REAR SEAT KIT



REAR SEAT KIT

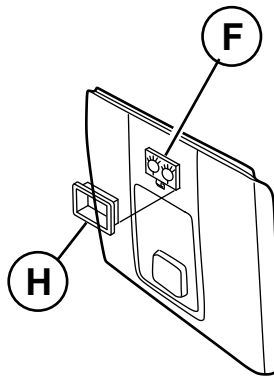

**52**

NOTE: REVERSE STEPS  
43, 30-27, 23-22, 19, 16-12  
AND 7-1 FOR RE-INSTAL-  
LATION

**53**

**A,B,C,D,M,N,J,O**    avant            arrière  
                              frente            parte posterior

**E**            avant  
                  (plus court)            arrière  
                  frente                    (plus longtemps)  
                  (más corto)            parte posterior  
  (más de largo)

**F,H,K** arrière  
                  parte posterior

**G,I,L** avant  
                  Frente

**2**            Note : répétition pour le côté oppose  
                  Nota: repetición para el lado opuesto

Couple à 32 pi-livres pour la reinstallation  
Esfuerzo de torsión a 32 pie-libras para la reinstalación

**5**            Couple à 32 pi-livres pour la reinstallation  
                  Esfuerzo de torsión a 32 pie-libras para la reinstalación

Avant de véhicule  
Frente del vehículo

**7**            Note : Employez l'article O pour réinstaller  
                  Nota: Utilice el artículo O para reinstalarse

**8,9,18,20**    Note : L'élément doit être porté sur le siège. L'espacement entre le bord de l'élément et l'arête intérieure de cushion/pad doit être égal au côté opposé.

Nota: El elemento se debe centrar en asiento. El espaciamento entre el borde del elemento y el canto interno de cushion/pad debe ser igual al lado opuesto.

Enlevez le support adhésif avant l'installation  
Quite el forro adhesivo antes de la instalación

**10,21** Note : Employez l'article J pour attacher la courroie comme nécessaire  
Nota: Utilice el artículo J para atar la correa según lo necesitado

**26**            Répétez les étapes 2-25 pour le côté oppose  
                  Repita los pasos 2-25 para el lado opuesto

**31,37,38,39,40,41,42** Répétition pour l'autre côté  
Repetición para el otro lado

**47** Calibre central sur la monture  
Plantilla de centro sobre bisel

**53** Note : Étapes renversées 43, 30-27, 23-22, 19, 16-12 et 7-1 pour la  
reinstallation  
Nota: Pasos reversos 43, 30-27, 23-22, 19, 16-12 y 7-1 para la  
reinstalación