

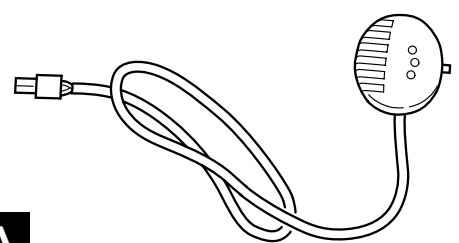

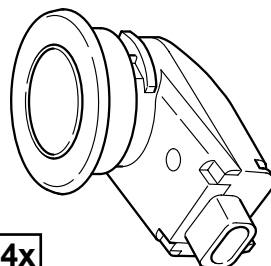

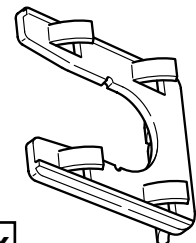

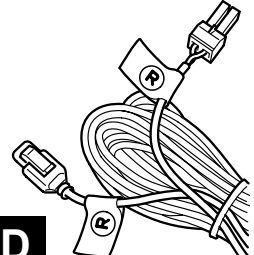

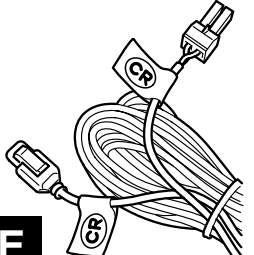
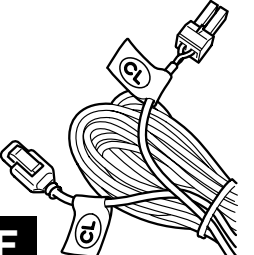
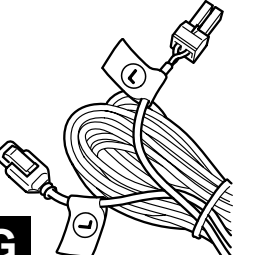
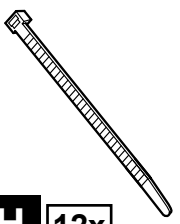
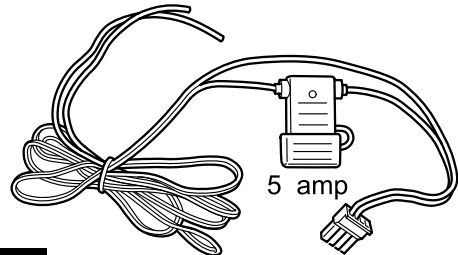
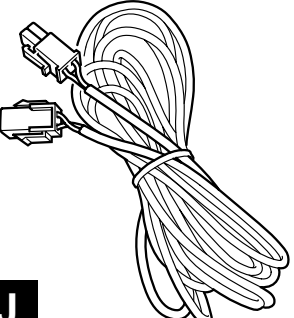
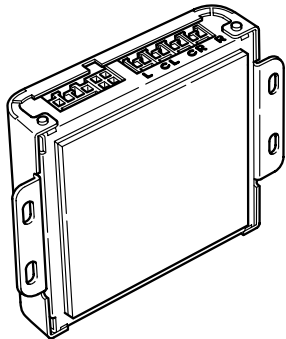
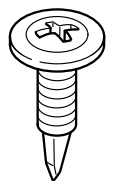
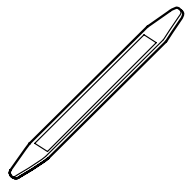
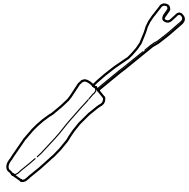
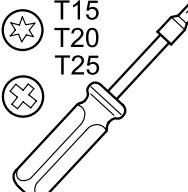
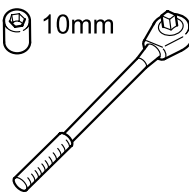
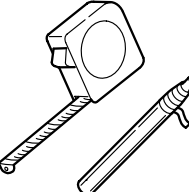
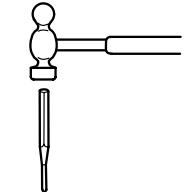
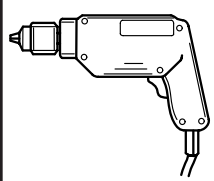

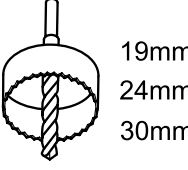
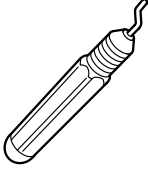
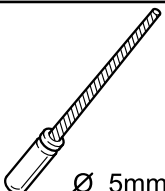
MOPAR®

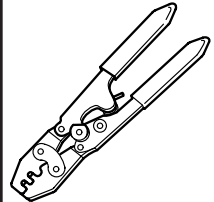
# 2005⇒ JEEP GRAND CHEROKEE

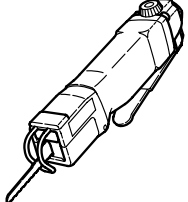
## Reverse Sensing System

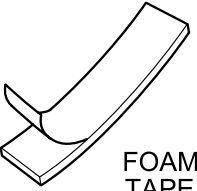
|  |   |   |   |   |  |
|--|---|---|---|---|--|
| <br><b>A</b>        | <br><b>B</b> 4x  | <br><b>C</b> 4x          |   |   |  |
| <br><b>D</b>        | <br><b>E</b>     | <br><b>F</b>               | <br><b>G</b>                       | <br><b>H</b> 12x |  |
| <br><b>I</b> 5 amp | <br><b>J</b>    | <br><b>K</b>            | <p>DO NOT USE</p> <br><b>L</b> 2x |   |  |
|                   |                | <br>T15<br>T20<br>T25    | <br>10mm                          |                |               |
|                   | <br>1/8" (3mm) | <br>19mm<br>24mm<br>30mm |                                    | <br>Ø 5mm      | <br>82300508  |
|                   |                |                          |                                    |                | <br>FOAM TAPE |

## IMPORTANT NOTES

## NOTAS IMPORTANTES

### GB

- Open the liftgate and remove the upper liftgate trim panel.
- Remove the right (passenger's side) D-pillar trim panel.
- Install audio/visual display to the right D-pillar trim panel as shown.
- Remove the lower liftgate trim panel.
- Remove the right C-pillar trim panel.
- Remove the right inner quarter trim panel.
- Remove the rear fascia and place it on a protected surface.
- If painting the sensors to match the vehicle color is desired by the customer, refer to the following 4 steps:
  - Step 1: Prep surface following standard paint shop procedures for painting of plastic components.
  - Step 2: Mix Sikkens Brand Autobase with Diluent 1:1.
  - Step 3: Fog-spray 1 coat of Autobase mixture. Wait 5 minutes. Wet-spray another coat of Autobase mixture. Let dry for 25 minutes.
  - Step 4: While Autobase is still wet, spray 1 coat of Autoclear (Varnish/Curing Agent/Diluent = 5:2 0:15). Let dry for 15 minutes. Place sensors in heated drying chamber for 60 minutes at 52°c.
- Install sensors as shown and fully engage the clips. Attach the sensor cables.
- Remove the right taillamp. Remove sealer patch from lower access hole in the taillamp opening panel.
- Drill an access hole in the right inner quarter panel as shown.
- Trim the rear fascia support in two places to allow clearance for the inboard sensor assemblies.
- Re-install rear fascia while carefully pulling the sensor cables into the vehicle. Keep cables away from sharp edges and ensure they are not pinched under the fascia. Replace any damaged plastic pop rivets from stock.
- Route power harness wires through the drilled access hole and out of the taillamp opening access hole.
- Determine which taillamp wires have the ground and back-up lamp signals. Disconnect the negative battery cable and perform center splicing as shown.
- Make all connections to the controller. Install controller using hook and loop patches.
- Loop up slack in cables and wires. Apply tie straps and tape and stow away neatly. Do not kink or tightly coil the cables.
- Re-install sealer patch to the taillamp access hole.
- Use foam tape around cables and wires at both access holes to prevent leaks.
- Connect audio/visual display cable to the extension cable.
- Re-connect battery and check operation of the reverse sensing system.
- The audio/visual display can be set to NO AUDIO, LOW AUDIO, or HIGH AUDIO.

### E

- 
- 
-

**NOTAS IMPORTANTES**

**REMARQUES IMPORTANTES**

**E**

**F**

- 
- 
-

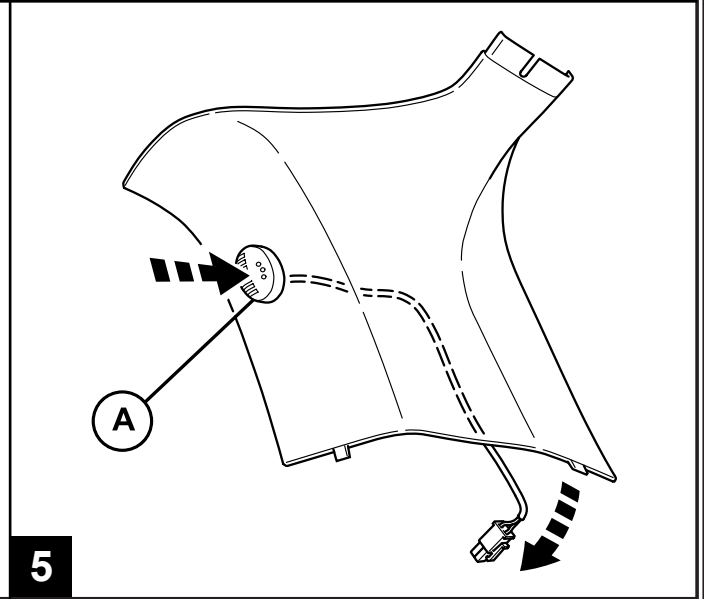
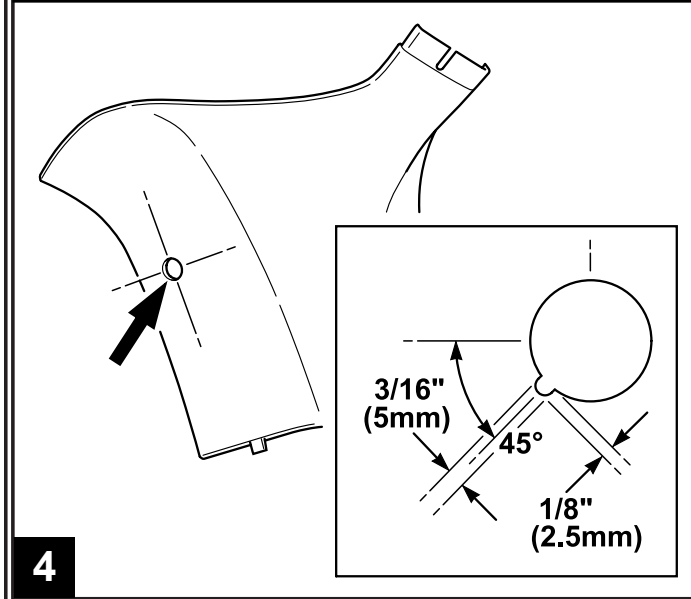
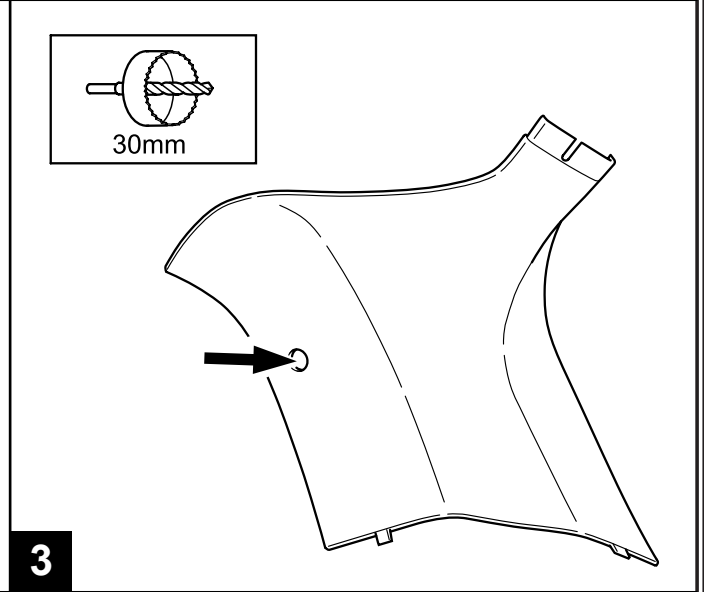
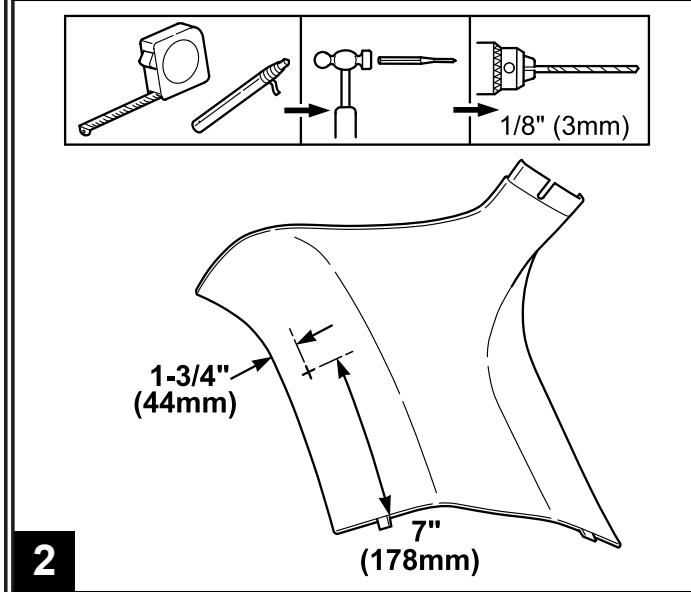
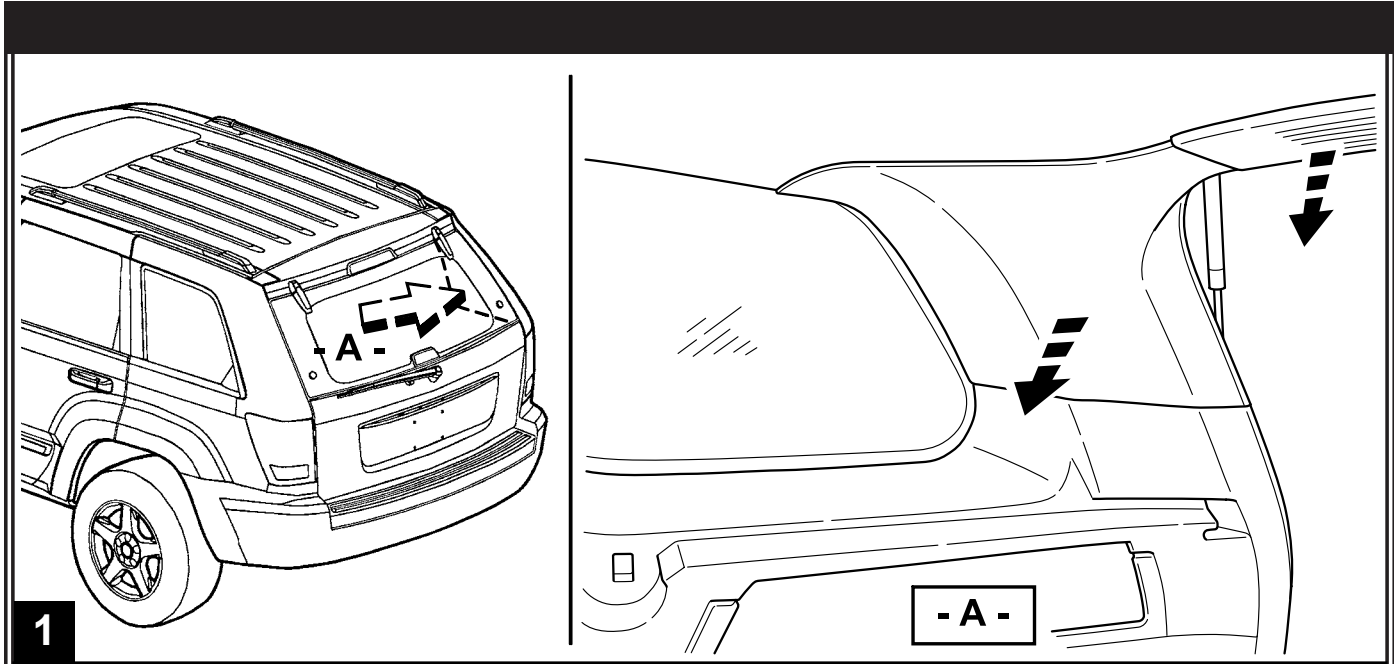

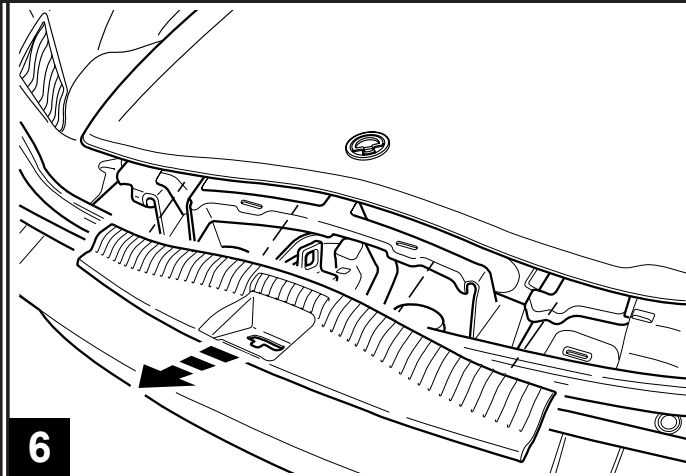

6

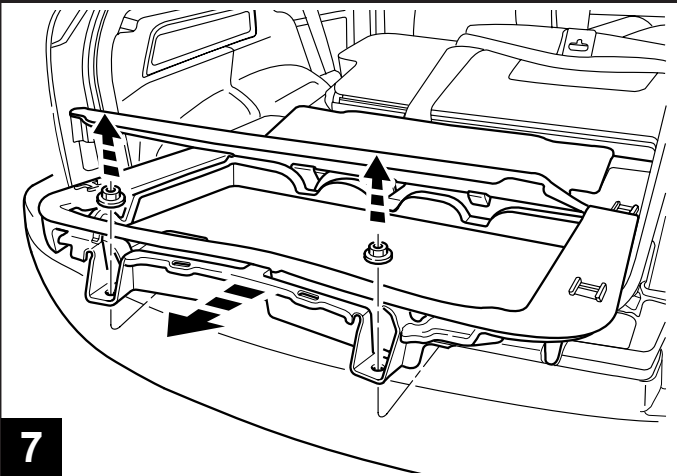

7

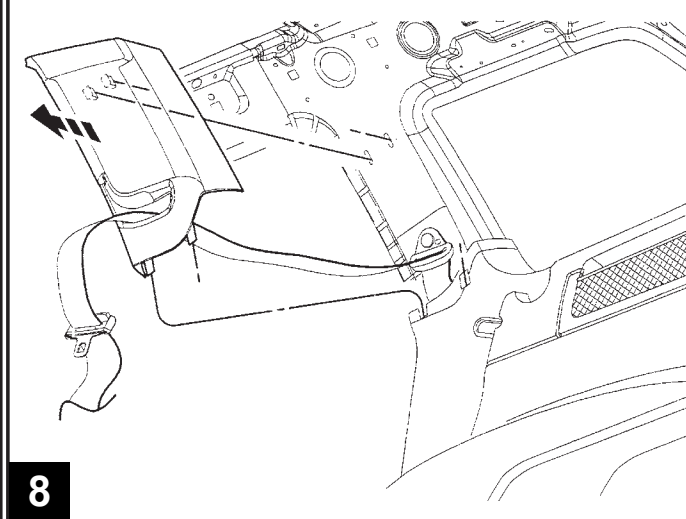

8

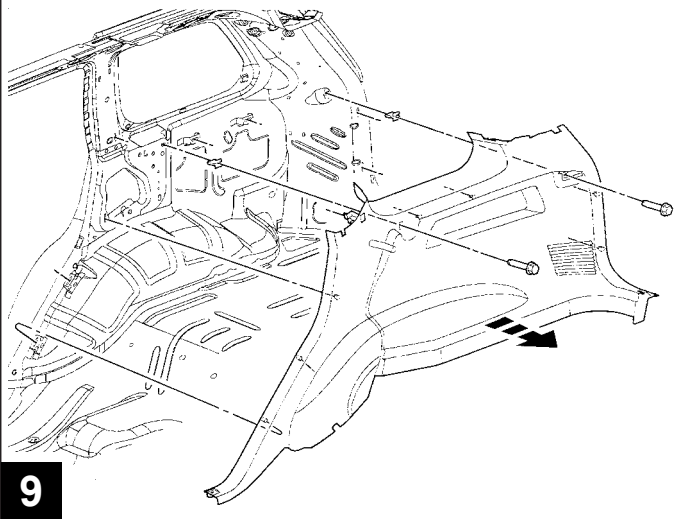

9

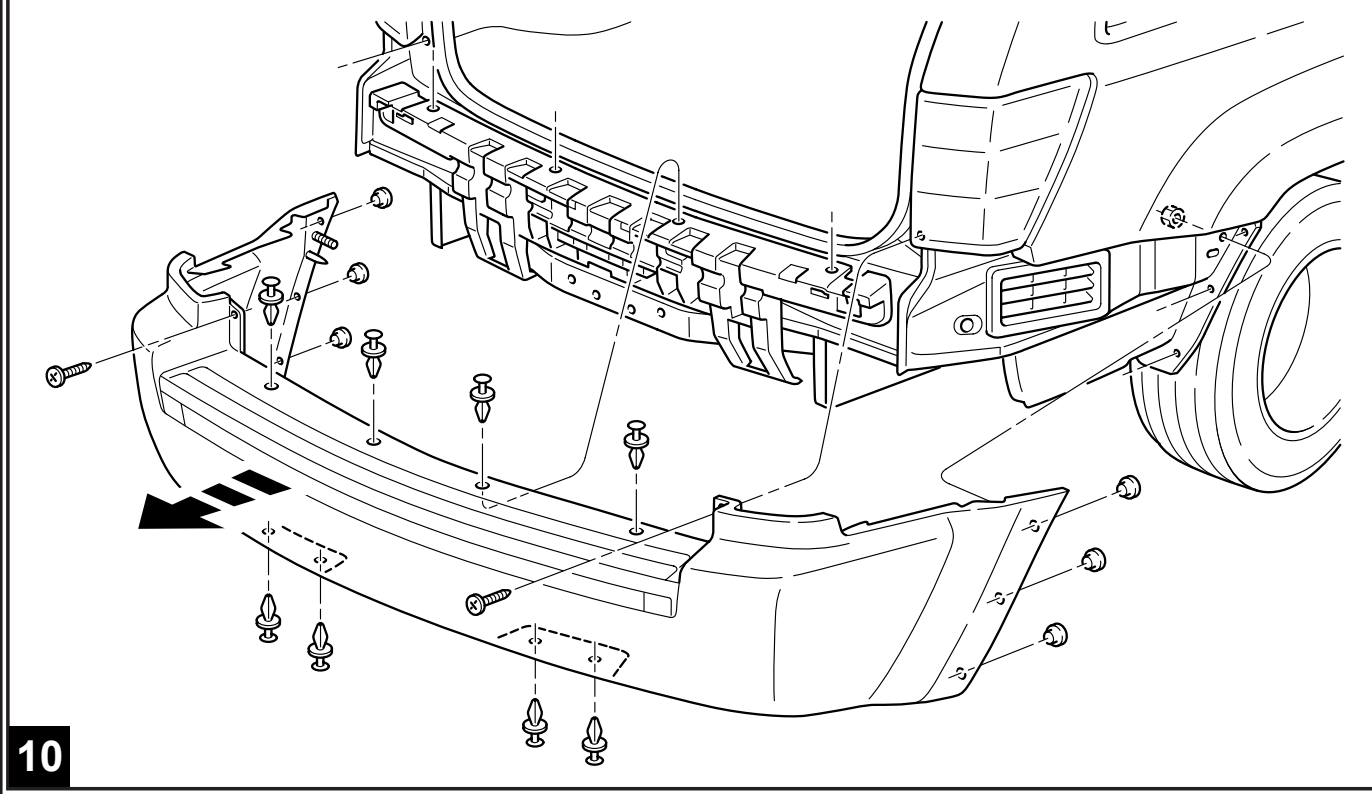

10

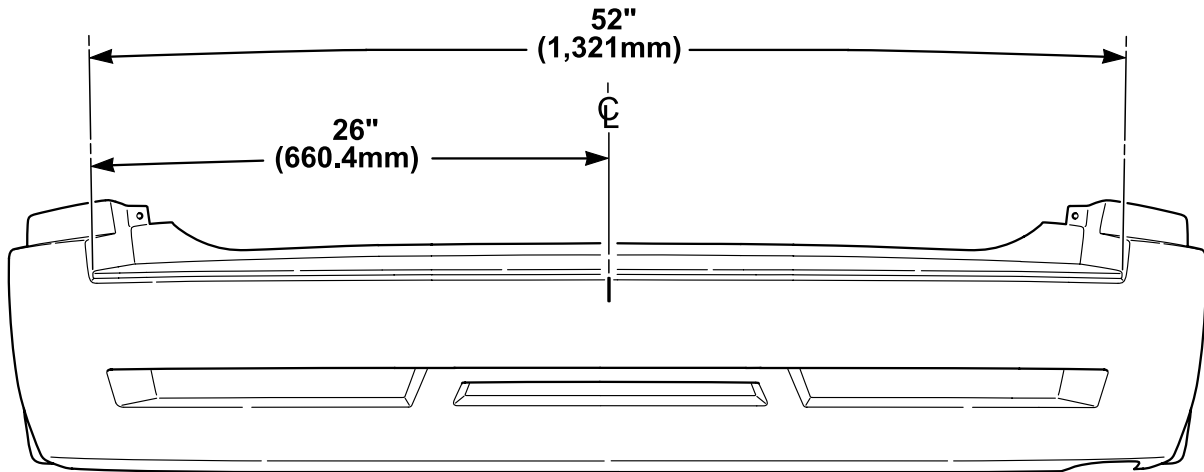
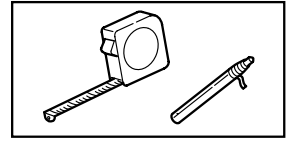

**11** LAREDO SHOWN, LIMITED SIMILAR.

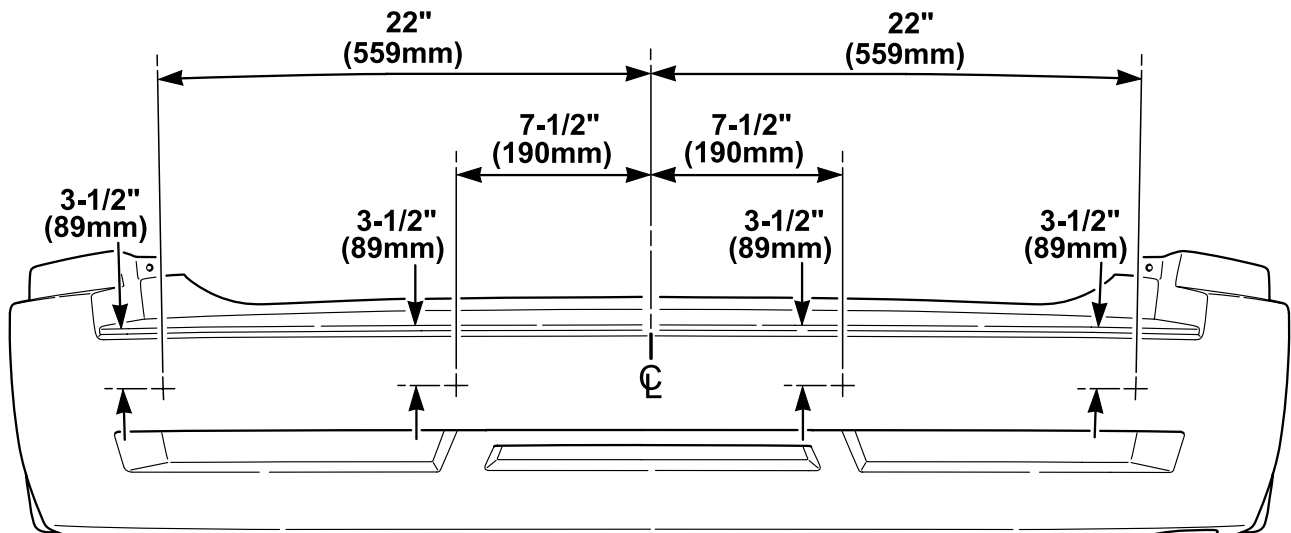
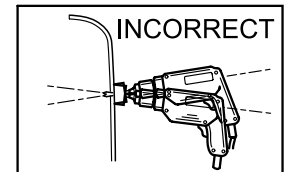
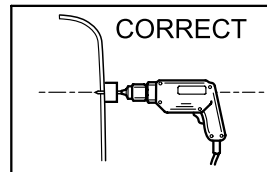
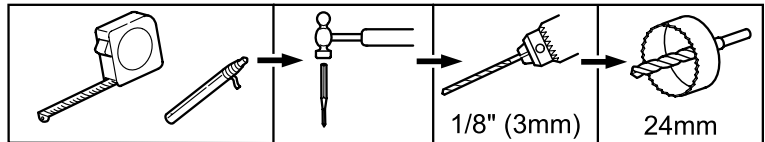
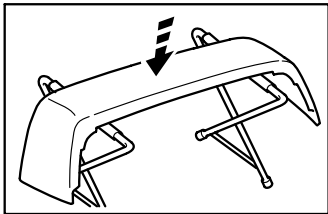

**12A** LAREDO ONLY.

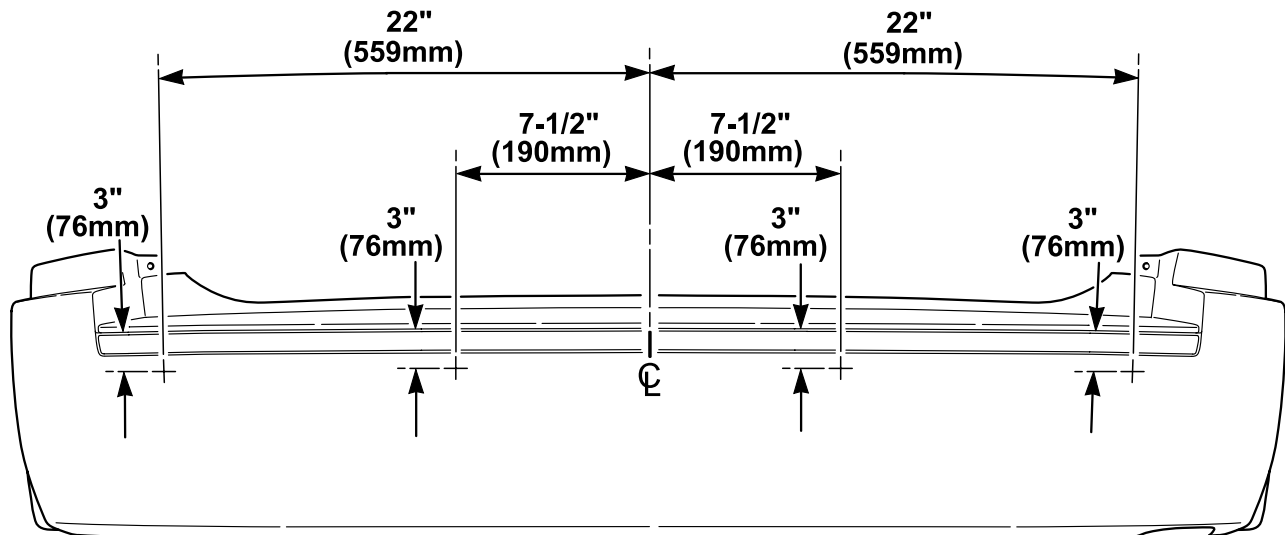
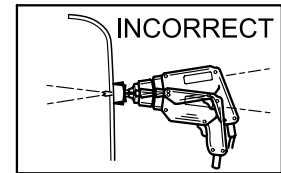
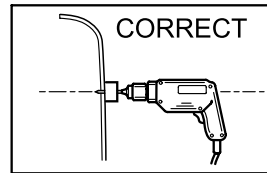
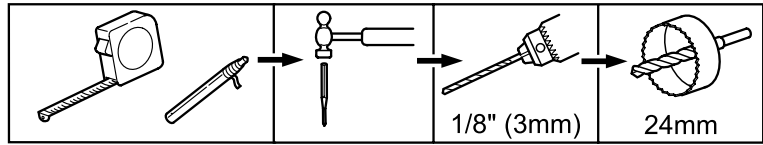
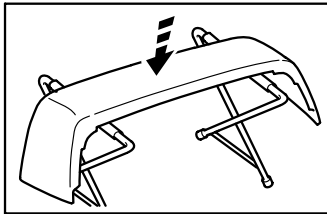

**12B** LIMITED ONLY.

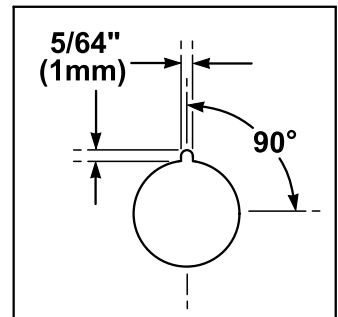
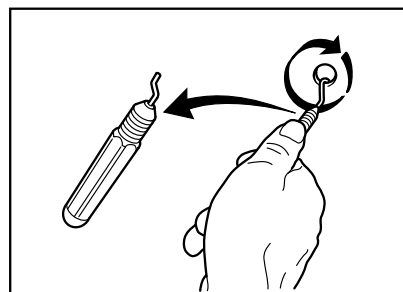
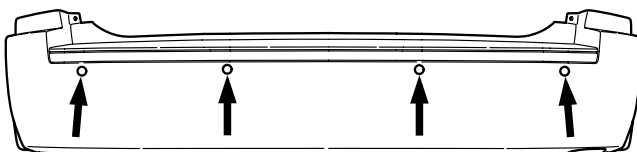

**13**

**14**

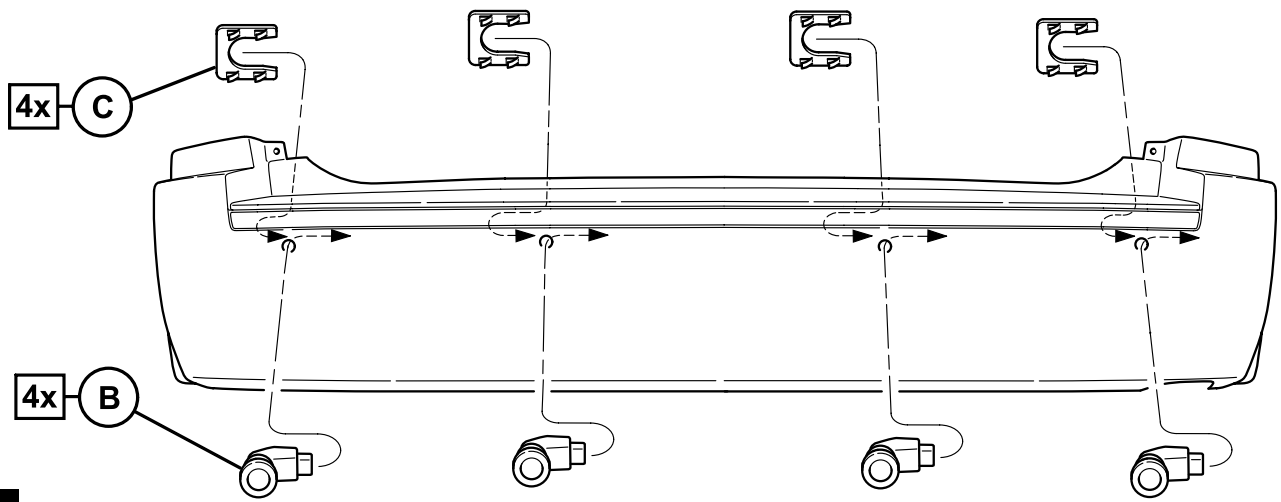

15

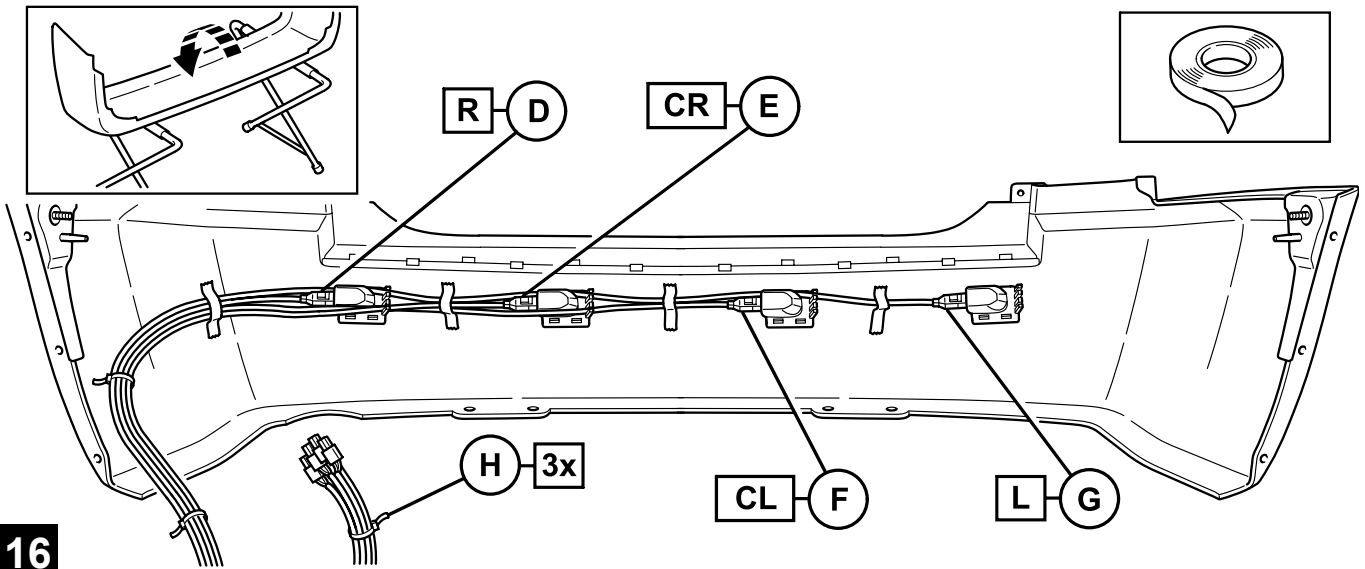

16

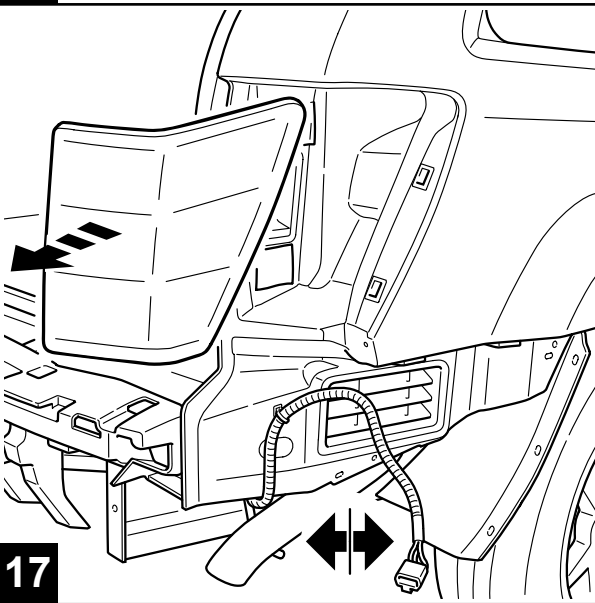

17

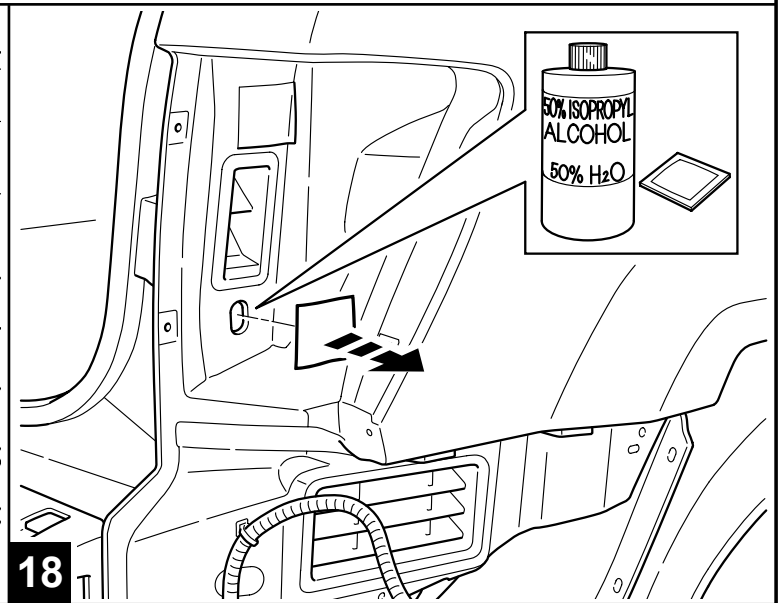

18



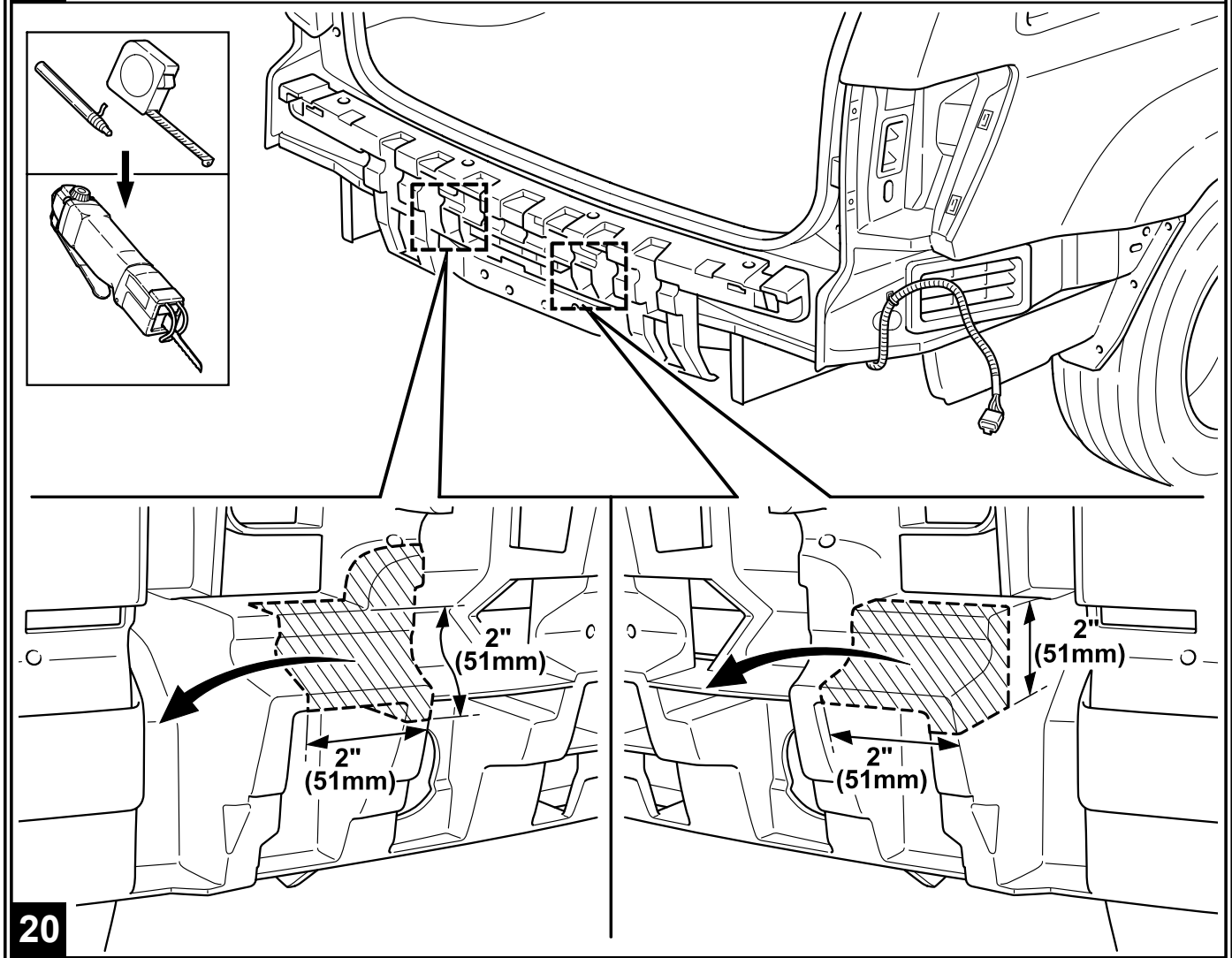
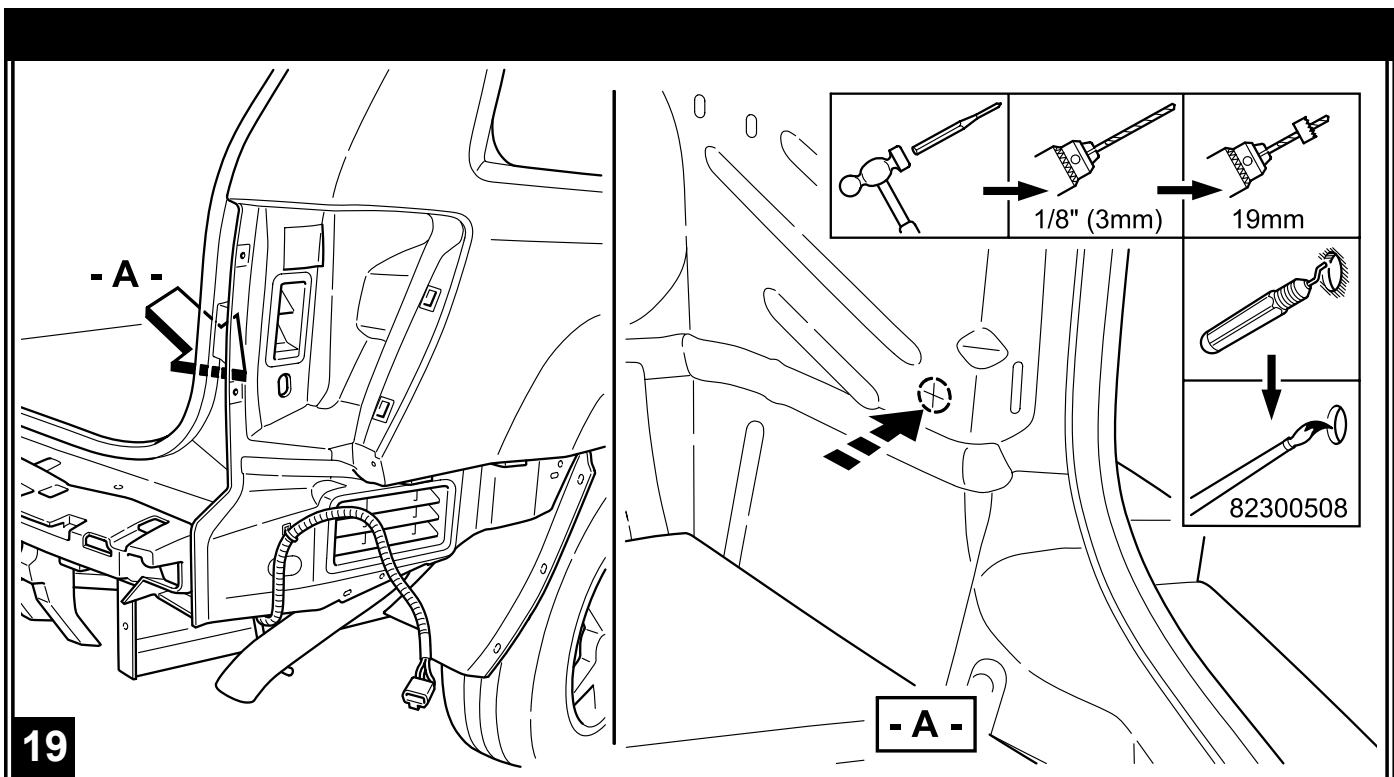

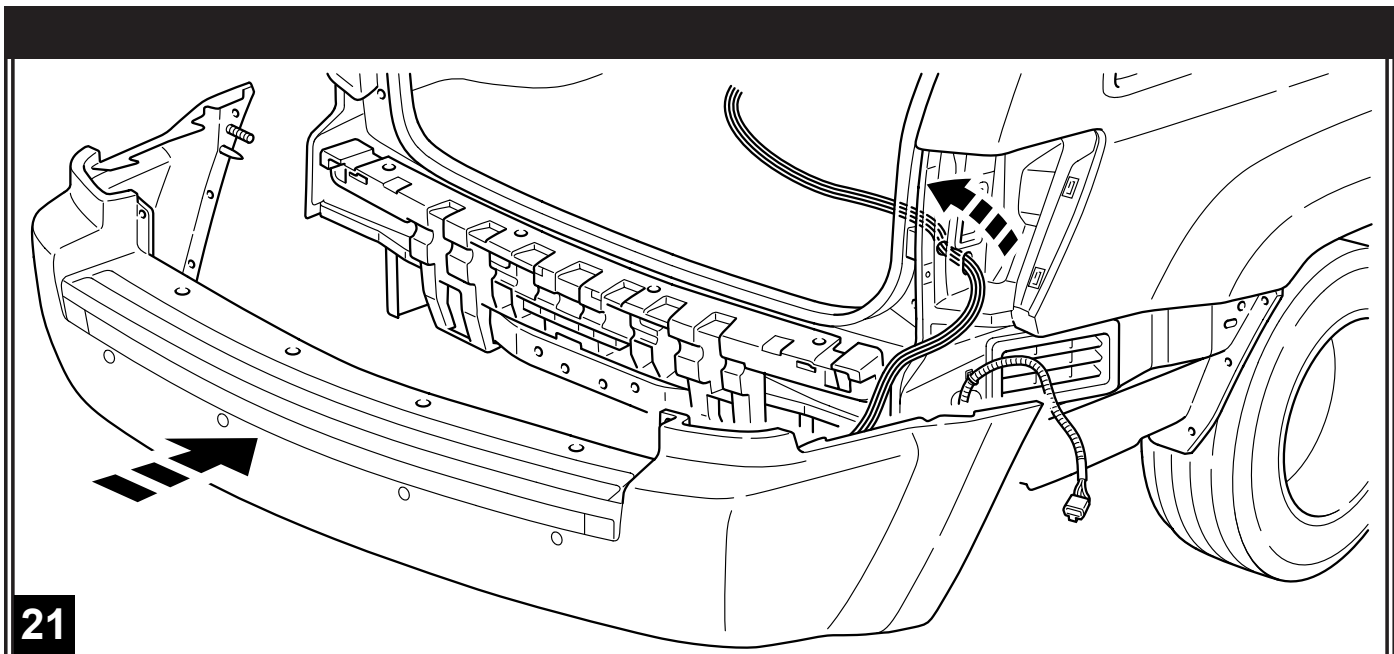

21

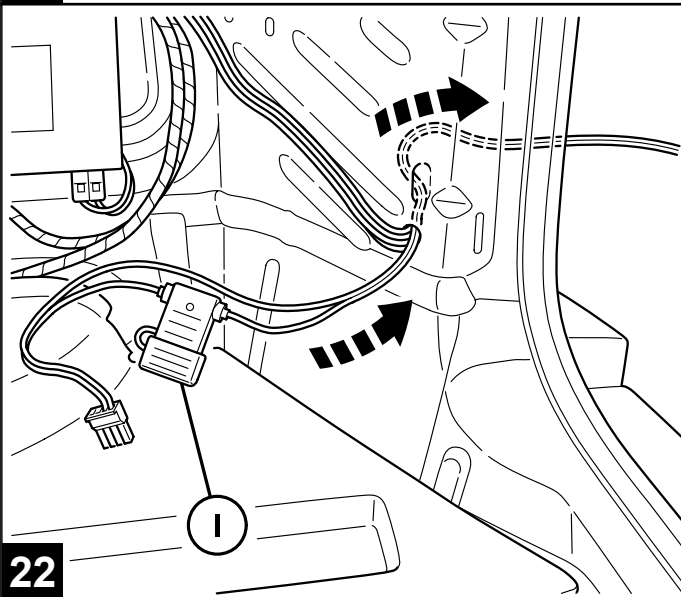

22

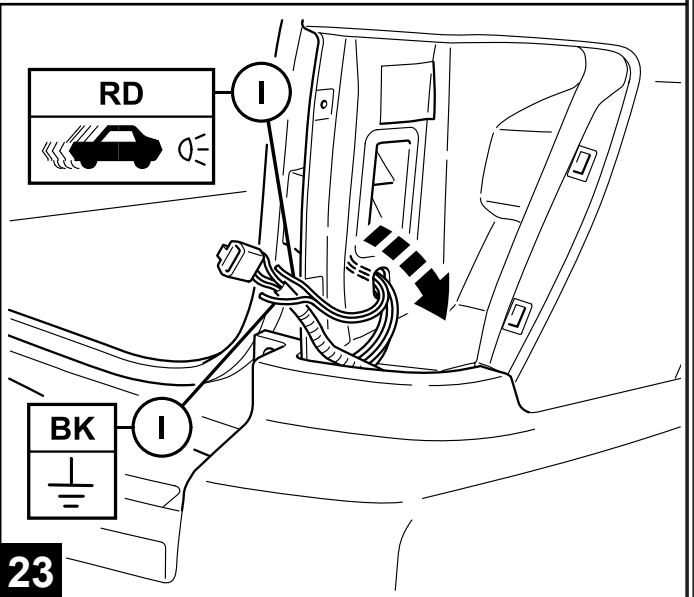

23

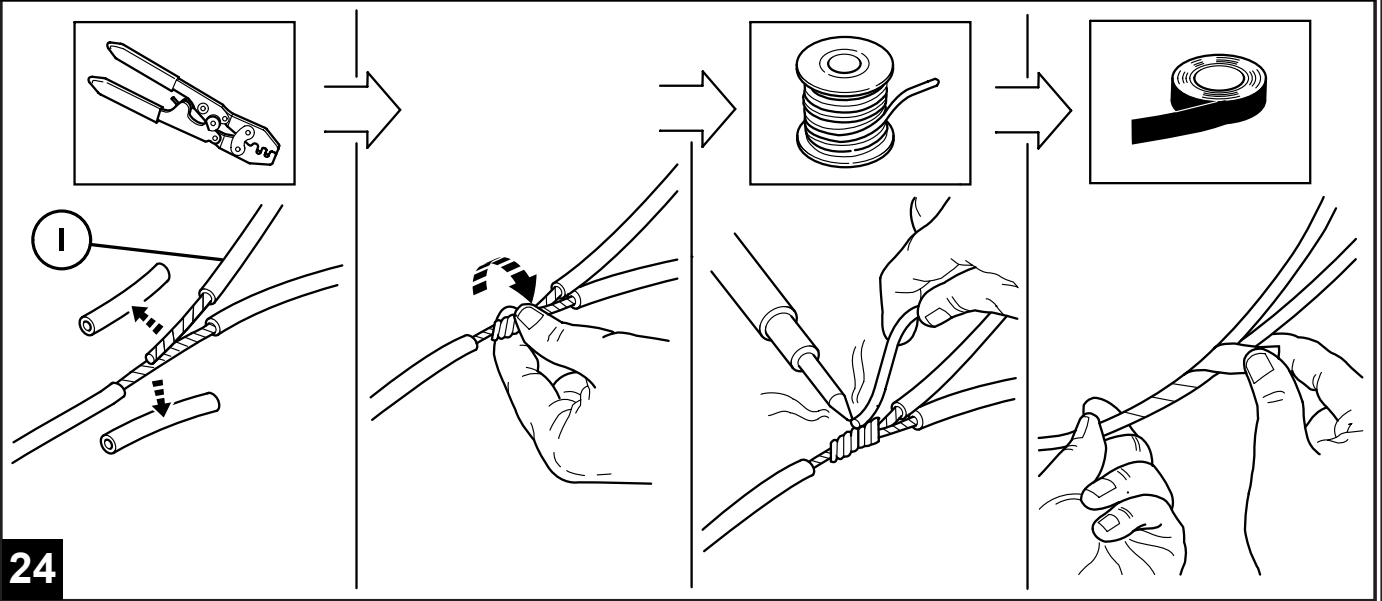

24

