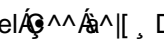

RADIO REMOVAL - 2009 DODGE RAM 1500

NOTE: For REQ radios, turn ignition to RUN and press the SET + SCAN buttons simultaneously to place the radio into transportation mode. The radio will display "Transportation" on the display within 5 seconds. If the radio is inoperative or not REQ, skip this step.

1. Disconnect and isolate the battery negative cable.
2. Remove the center instrument panel bezel. 
3. Remove the radio mounting fasteners.

CAUTION: Pulling the antenna cable straight out of the radio without pulling on the locking antenna connector could damage the cable or radio.

4. Disconnect the antenna cable(s) by pulling the locking antenna connector away from the radio.
5. Disconnect the electrical connectors.

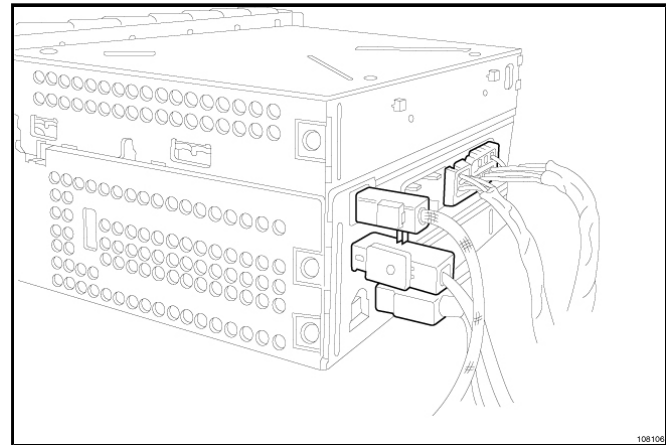

WARNING: On vehicles equipped with airbags, disable the airbag system before attempting any steering wheel, steering column, seat belt tensioner, or instrument panel component diagnosis or service. Disconnect and isolate the battery negative (ground) cable, then wait two minutes for the airbag system capacitor to discharge before performing further diagnosis or service. This is the only sure way to disable the airbag system. Failure to take the proper precautions could result in accidental airbag deployment and personal or fatal injury .

1. Disconnect and isolate the negative battery cable.
2. Remove the upper and lower center bezel tray liners (1).

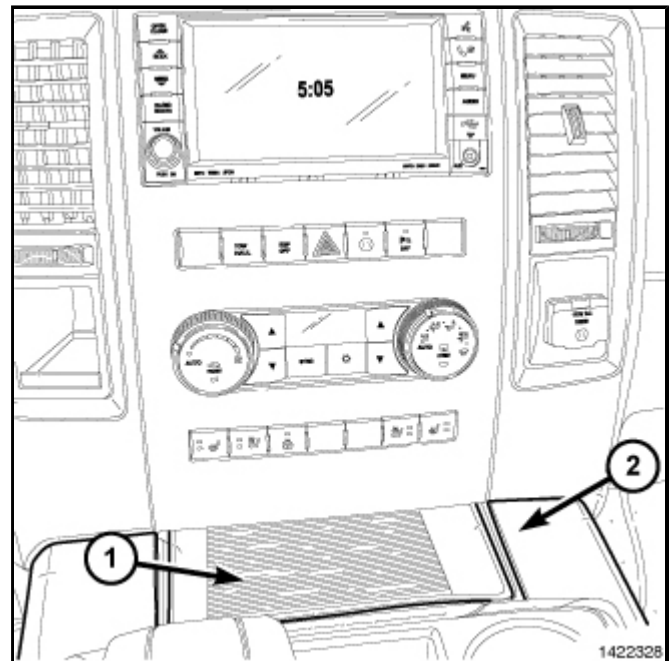
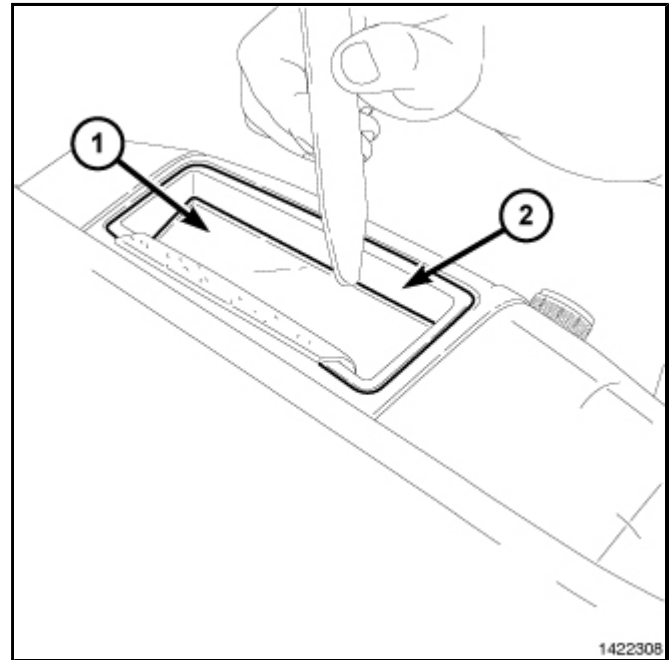

3. Using a trim stick C-4755 or equivalent, disengage the retain clips that secure the power outlet trim bezel (1) to the center bezel (2).

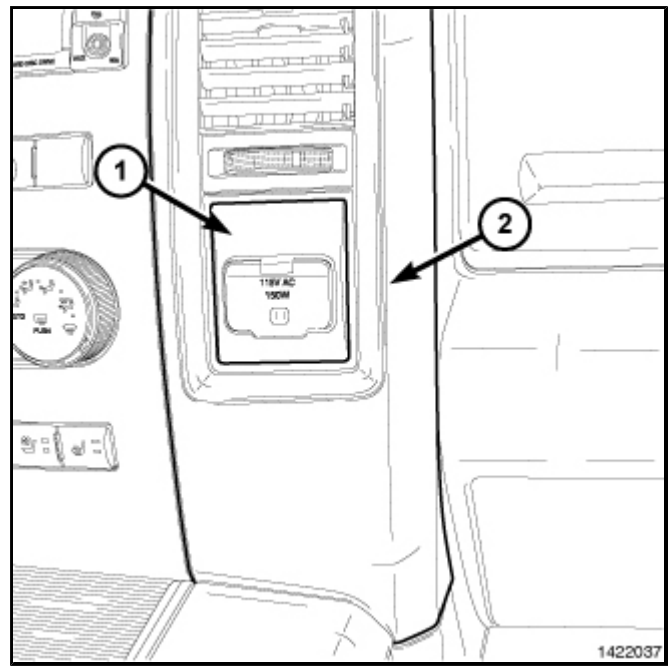

4. Remove the five center bezel fasteners(1).

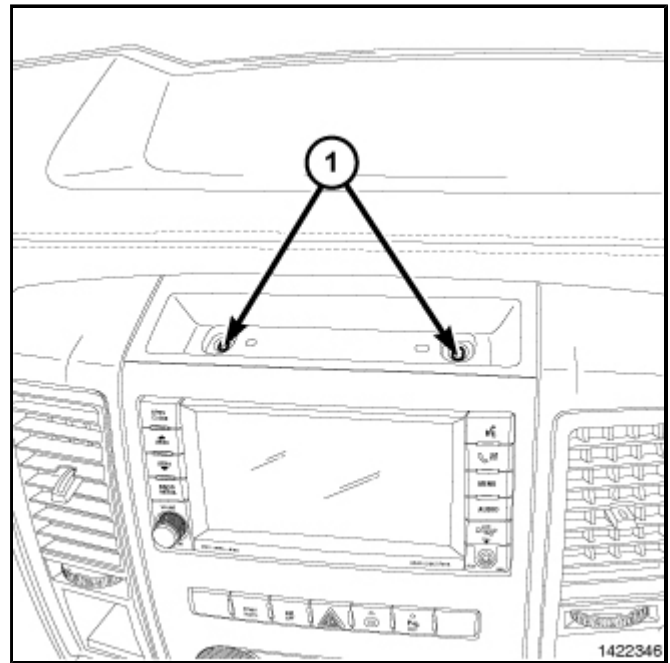

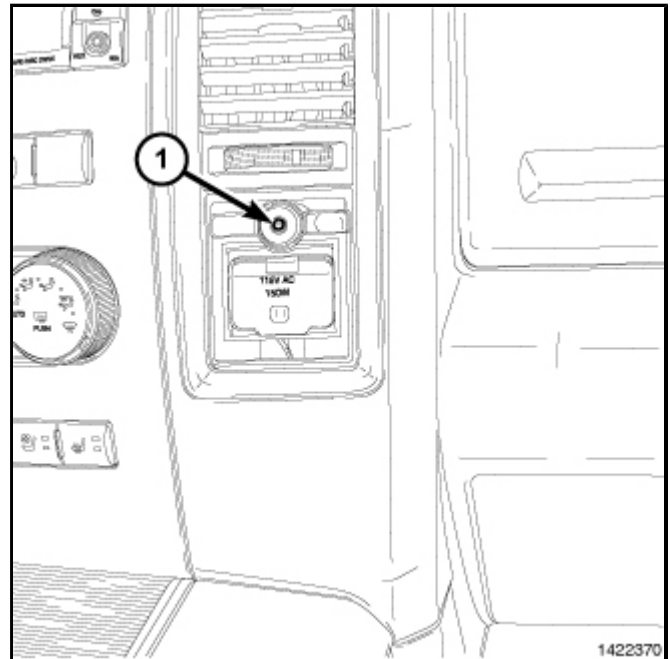
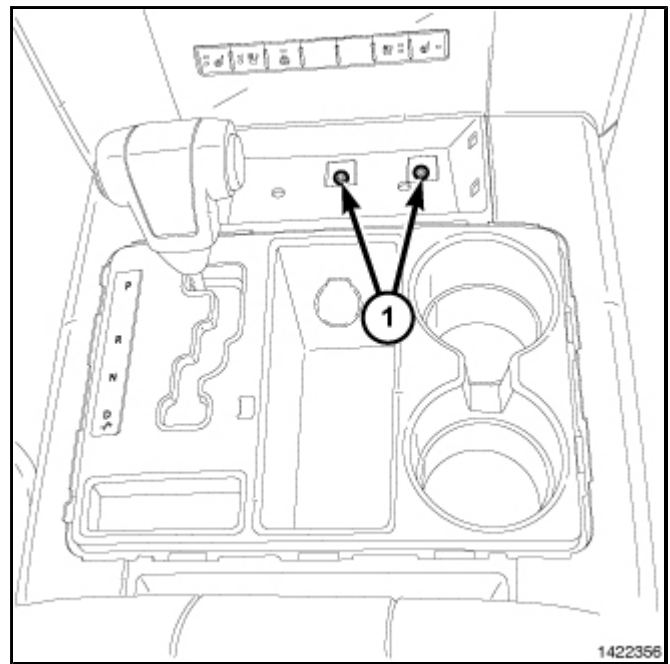

5. Using a trim stick C-4755 or equivalent, disengage the retainer clips that secure the trim ring to the floor console.

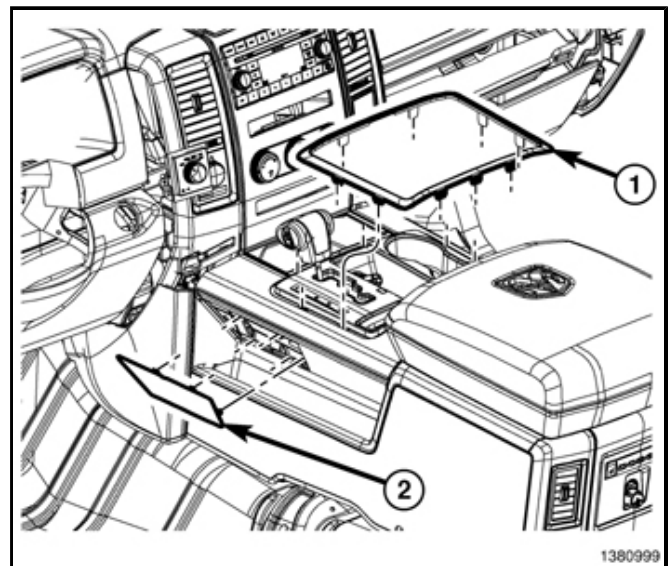

6. Using a trim stick C-4755 or equivalent, disengage the retainer

clips that secure the shifter bezel to the floor console

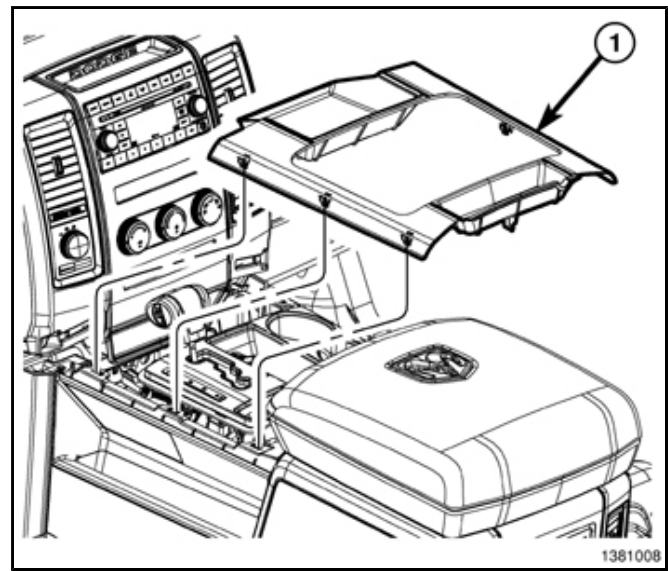

7. Using a trim stick C-4755 or equivalent, disengage the retainer clips that secure the instrument panel center bezel (1) to the instrument panel.
8. Disconnect the wire harness connectors (4) and remove the center bezel from the vehicle.

