



**NUMBER:** 09-005-07

**GROUP:** Engine

**DATE:** October 2, 2007

*This bulletin is supplied as technical information only and is not an authorization for repair. No part of this publication may be reproduced, stored in a retrieval system, or transmitted, in any form or by any means, electronic, mechanical, photocopying, or otherwise, without written permission of Chrysler LLC.*

**SUBJECT:**

3.0L Diesel Oil Filter Cap Service

**MODELS:**

2006 - 2008	(LE)	300C/300C Touring (International Markets)
2007 - 2008	(WK)	Grand Cherokee
2005 - 2008	(WH)	Grand Cherokee (International Markets)
2006 - 2008	(XH)	Commander (International Markets)

**DISCUSSION:**

When servicing the oil filter on the 3.0L diesel engine make sure that the O-ring on the oil filter cap is properly installed. The O-ring needs to be located in proper groove ([Fig. 1](#)). Insure that the O-ring is not cut or torn.

If the O-ring is not properly installed you may notice that the O-ring is rolled out along the seal.



**Stick with the Specialists™**

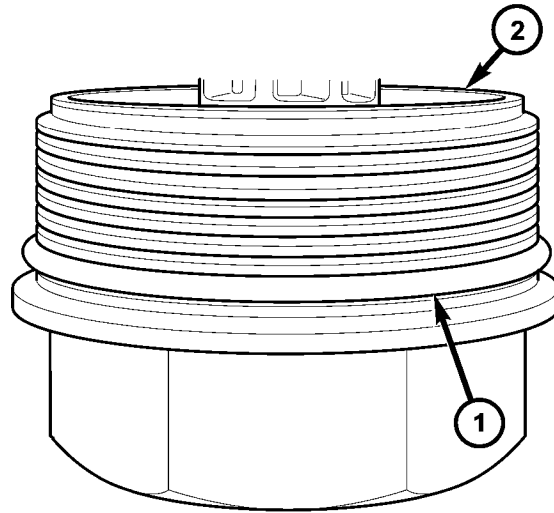

81eea521

**Fig. 1 O-RING LOCATION**

1 - O-ring Correct Location

2 - Oil Filter Cap

---

**POLICY:**  
Information Only